

OPERATION AND MAINTENANCE HANDBOOK
FOR

MODEL 608D
VHF SIGNAL GENERATOR
code 2752

ERRATA

- Page 2, Paragraph 1-3, line 14:
change "0.5 milliwatt" to "0.1 milliwatt".
- Page 4, Specifications, Output Level Calibration Accuracy:
change " ± 2 decibels" to " ± 1 decibel".
- Page 4, Specifications, External Sine Wave Modulation:
change "4 to 25-volt rms signal required" to
"0.5-volt rms or better required".
- Page 4, Specifications, External Pulse Modulation:
change "Positive 10-volt peak pulse required" to
"Positive 5-volt peak pulse required".
- Page 8, Figure 2, item 20:
arrow should point to recessed screw above ZERO

*noted in text
12/20/55*

OPERATION AND MAINTENANCE HANDBOOK
FOR

MODEL 608D
VHF SIGNAL GENERATOR

Copyright 1955 by Hewlett-Packard Company

The information contained in this booklet is intended for the operation and maintenance of Hewlett-Packard equipment and is not to be used otherwise or reproduced without the written consent of the Hewlett-Packard Company.

HEWLETT-PACKARD COMPANY
275 PAGE MILL ROAD, PALO ALTO, CALIFORNIA, U. S. A.

TABLE OF CONTENTS

MODEL 608D

VHF SIGNAL GENERATOR

		<u>Page No.</u>
Section I	GENERAL DESCRIPTION	
	1-1 Introductory	1
	1-2 Auxiliary Equipment	1
	1-3 General Electrical Characteristics	2
Section II	INSTALLATION AND OPERATION	
	2-1 Introductory	5
	2-2 Installation	5
	2-3 Operating Controls, Dials, and Terminals	5
	2-4 Turning on the Equipment	6
	2-5 Continuous Wave Operation	11
	2-6 Internal Sine Wave Modulation	12
	2-7 External Sine Wave Modulation	13
	2-8 Pulse Modulation	14
	2-9 Crystal-Controlled Beat Frequency Calibrator	15
	2-10 Signal Generator Loading Considerations	15
	2-11 Fine Freq. Adjust, Control	16a
Section III	THEORY OF OPERATION	
	3-1 General	17
	3-2 Radio Frequency Oscillator	19
	3-3 Radio Frequency Buffer	20
	3-4 Radio Frequency Power Amplifier	21
	3-5 Output Attenuator and R-F Power Monitor	22
	3-6 Xtal (Beat Frequency) Calibrator	23
	3-7 Modulator Section	24
	3-8 Modulation-Measuring Circuits	26
	3-9 Power Supply	26
	3-10 Heater Supply Multivibrator	27

608D 5/19/55 Serial 192 and above #608D006

TABLE OF CONTENTS (Contd.)

	<u>Page No.</u>
Section IV MAINTENANCE	
4-1 Introduction	29
4-2 Cabinet Removal	31
4-3 Periodic Checks and Routine Care	31
4-4 Localizing Trouble	33
4-5 Power Supply Trouble Shooting and Adjustment	34
4-6 System Analysis Check Chart	36
4-7 Replacement of Electron Tubes	41
4-8 Radio Frequency Oscillator Tube Replacement	43
4-9 Radio Frequency Amplifier and Buffer Tube Replacement	45
4-10 Xtal Frequency Oscillator Tube or Crystal Replacement	47
4-11 Replacement of Electron Tubes Within the Regulated Power Supplies	49
4-12 Attenuator Probe Replacement	51
4-13 Replacement of Lamp II	54
4-14 Calibration of the Percent Modulation Meter	54
4-15 Output Volts Meter Calibration and R-F Power Monitor Service	57
4-16 Repairing the Calibrator Oscillator	61
4-17 Trouble Shooting Chart	62

LIST OF ILLUSTRATIONS

<u>Figure</u>	<u>Title</u>	<u>Page No.</u>
1	VHF Signal Generator -hp- Model 608D	Frontispiece
2	Model 608D Signal Generator Front Panel Controls	8
3	Diagram Showing Relationships of Front Panel Controls to Major Circuits	10
4	Block Diagram for Signal Generator 608D	18
5	Cabinet Removal Diagram	30
6	R-F Tuner Drive Mechanism	32
7	Tube Location Diagram	42
8	R-F Oscillator and Amplifier Tube Replacement Diagram	44
9	Diagram Showing Adjustment for Internal Freq. Calibrator	46
10	R-F Generator Assembly Rear View, Showing Output Attenuator Drive System	48
11	R-F Output Attenuator Probe, Showing Pickup Loop and Impedance Matching Network	50
12	Model 608D Signal Generator Right Side View, Cabinet Removed	64
13	Model 608D Signal Generator Rear View, Cabinet Removed	65
14	Model 608D Signal Generator Left Side View, Cabinet Removed	66
15	R-F Generator Assembly, Side Plate Removed to Show Tuning Compartments	67
16	Tube Compartment of R-F Generator Assembly, Frequency Dial and Cover Plate Removed	68
17	Signal Tracing Block Diagram	69
18	Tube Socket Voltage and Resistance Diagram, Right Side Chassis	71
19	Tube Socket Voltage and Resistance Diagram, Rear Chassis	73
20	Tube Socket Voltage and Resistance Diagram, R-F Generator Assembly	75



Fig. 1. VHF Signal Generator -hp- Model 608D

SECTION I

GENERAL DESCRIPTION

1-1 INTRODUCTORY

The Hewlett-Packard Model 608D VHF Signal Generator is a general purpose test instrument which furnishes accurately adjustable radio frequency signals from 0.1 microvolt to 0.5 volt over the frequency range from 10 to 420 megacycles and which may be amplitude modulated by internally generated sine waves or by externally applied sine waves or pulses. The 608D includes a built-in crystal-controlled heterodyne calibrator which permits the operator to adjust the output frequency very accurately at check points every 5 megacycles over the full frequency range of the instrument. The output signal level is adjusted by an attenuator calibrated in both volts and dbm and can be read directly to an accuracy of ± 1 db over the full frequency range without the use of external pads, monitoring devices, or charts. The 608D features straightforward operation through the use of reliable, direct-reading controls and meters throughout. With its high quality output signal, the -hp- Model 608D is especially suitable for applications requiring a minimum of incidental amplitude or frequency modulation.

The Model 608D Signal Generator is designed to meet the exacting requirements of precision laboratory work and yet to be equally useful for general applications in the 10 to 420 megacycle frequency range. The equipment can be used for testing, calibrating, and trouble shooting VHF radio equipment and circuits and for measuring standing wave ratios, antenna and transmission line characteristics, receiver sensitivity, etc. To obtain utmost accuracy in this type of application, particular care has been taken in the design of the 608D to hold spurious modulation to a very low value under all operating conditions.

1-2 AUXILIARY EQUIPMENT

The Model 608D Signal Generator is a complete test equipment ready for use as received from the factory. A special wrench necessary for removing the r-f amplifier tube is supplied and is mounted on the instrument chassis. To use the crystal calibrator included in the equipment, an earphone headset must be provided by the operator. For external modulation of the signal generator, an external source of modulating voltage must be provided by the operator. A special coaxial fuseholder for protection to the output

attenuator is available as an accessory. This fuse protects the output attenuator from damage in the event that an external voltage is accidentally applied to the RF OUTPUT jack. The fuseholder connects directly to the output jack and is provided with a standard female type N output jack. A type 8AG, 1/16 amp fuse is utilized. The fuseholder has an insertion loss of 0.50 db at 200 mc, 0.56 db at 300 mc, and 0.65 db at 400 mc; and its VSWR is not greater than 1.35 when connected to a 50-ohm resistive load.

1-3 GENERAL ELECTRICAL CHARACTERISTICS

The Model 608D generates r-f output signals over the frequency range from 10 to 420 megacycles which are indicated on a direct-reading dial. The frequency dial calibration is accurate to better than 1% when the movable index is in its original position as indicated by the alignment of the adjustment knob with the white line on the panel. Calibration accuracy may be improved by employing the crystal-controlled heterodyne calibrator, which provides check points at every 5 megacycles over the entire frequency range of the equipment. The frequency dial index is adjustable from the front panel so that at any check point the calibration may be set very close to the calibrator accuracy of 0.01%. The check-point signals are obtained by connecting an earphone set (not part of the equipment) to the XTAL CAL. OUTPUT jack. The calibrator is capable of providing up to ~~0.5~~ milliwatt of power to a 600-ohm headset and is adjustable by the XTAL CAL. GAIN control.

An output attenuator, calibrated to be read directly in both volts and decibels, continuously varies the output signal from +4 to -127 dbm (350 millivolts to 0.1 microvolt) and may be read to an accuracy of ± 1 db or better over the entire frequency and attenuation range when connected to an external 50-ohm resistive load. The internal impedance of the generator, as seen at the output jack, is nominally 50 ohms over the full frequency range; and when connected to a 50-ohm resistive load, the VSWR due to mismatch will not be greater than 1.2 (SWR of 1.6 db).

The r-f output signal from the 608D may be amplitude modulated by internally generated 400- and 1000-cycle sine waves or by externally applied sine waves above .5 volt rms over the frequency range from 20 cps to 100 kc or by externally applied pulses above approximately 10 volts. When pulse modulated, the 608D is capable of generating pulses of radio frequency energy as short as 4 microseconds at r-f signal frequencies above 40 megacycles and pulses as short as 1 microsecond above 220 megacycles. The degree of sine wave modulation is continuously variable from 0 to 95% by a front panel control. All sine wave modulation of the r-f output

signal is continuously monitored and indicated in percentage on a direct-reading modulation meter having an accuracy of $\pm 10\%$ of the meter indication at readings between 30 and 95%.

The envelope of the sine wave modulated signal contains less than 5% distortion. Incidental amplitude modulation of the CW output signal is less than 0.1%. The total level of harmonics and spurious signals contained in the CW output signal is 40 decibels below the level of the output signal when the output level is greater than 200 microvolts.

R-f leakage is held to a minimum and is such that when the output signal is adjusted for 0.1 microvolt, the conducted signal leakage at any other front panel connector and the radiated leakage two inches from the instrument are each less than 1.0 microvolt.

The 608D is 13-3/4 inches wide by 16 inches high by 20 inches deep and weighs 64 pounds. The instrument is housed in an aluminum cabinet finished in gray baked enamel. Guard-rail type handles are provided to assist in handling and to protect the front panel controls. Ventilation is provided by louvers in the side and back surfaces of the cabinet. The chassis is removable by loosening the four screws in the rear of the cabinet.

608D 5/19/55 Serial 192 and above #608D006

SPECIFICATIONS FOR THE MODEL 608D SIGNAL GENERATOR

FREQUENCY RANGE:	10 to 420 megacycles covered in five bands.
ACCURACY OF FREQUENCY CALIBRATION:	With crystal calibrator, $\pm 0.05\%$ at check points. Without calibrator, $\pm 0.5\%$ overall.
CRYSTAL CALIBRATOR:	5 megacycle oscillator accurate to $\pm 0.01\%$ providing check points at each 5 megacycles over full frequency range. Provides 0.1 milliwatt or better to 600-ohm earphone set.
OUTPUT VOLTAGE:	Continuously adjustable from 0.1 microvolt minimum to 0.5 volt maximum when operated into rated load of 50 ohms.
OUTPUT LEVEL METER:	Monitors r-f power level fed to output attenuator; calibrated 0 to 7 dbm and 0.1 to 0.5 volt.
OUTPUT LEVEL CALIBRATION ACCURACY:	For all conditions of operation the accuracy of the attenuator dial is within ± 2 decibels when operated with 50-ohm load.
RATED LOAD:	Nominally 50 ohms resistive.
OUTPUT CIRCUIT STANDING WAVE RATIO:	The VSWR measured at the output connector is less than 1.2 (SWR 1.6 db).
INTERNAL MODULATION:	Sine waves at frequencies of 400 and 1000 cps $\pm 5\%$. Percent modulation continuously adjustable from zero to 95% at output levels up to 0 dbm.
EXTERNAL SINE WAVE MODULATION:	<i>.5 volt RMS OR BETTER</i> 4 to 25 volt rms signal required. Percent modulation continuously adjustable from 0 to 95% at output levels of 0 dbm and below for modulating frequencies from 100 cps to above 20,000 cps.
PERCENT MODULATION:	Indicated by direct-reading panel meter accurate to $\pm 10\%$.
ENVELOPE DISTORTION FOR SINE WAVE MODULATION:	Less than 5% at 30% modulation for frequencies from 100 to 5000 cps. Less than 10% at 50% modulation.
INPUT IMPEDANCE FOR EXT SINE MODULATION:	20,000 ohms shunted by 50 micromicrofarads.
EXTERNAL PULSE MODULATION:	Positive 10 ⁵ volt peak pulse required. Combined rise and decay time of r-f output pulse less than 4 microseconds from 40 mc to 220 mc; less than 1 microsecond from 220 to 420 megacycles. Residual level at least 20 db below 0.5 peak pulse output.
INPUT IMPEDANCE FOR EXT PULSE MODULATION:	50,000 ohms shunted by 40 micromicrofarads.
FREQUENCY STABILITY:	Frequency drift less than 0.005% over a 10 minute interval after initial instrument warm-up.
RESETABILITY:	Better than $\pm 0.1\%$ after initial instrument warm-up.
RESIDUAL FREQUENCY MODULATION:	Less than 1,000 cycles at 50% amplitude modulation for RF output frequencies above 100 mc and less than 0.001% at RF output frequencies below 100 mc.
LEAKAGE:	Negligible; permits receiver sensitivity measurements down to at least 0.1 microvolt.

608D 5/19/55 Serial 192 and above #608D006

SECTION II
INSTALLATION AND OPERATION

2-1 INTRODUCTORY

This section contains instructions for installing and operating the Model 608D Signal Generator. The information contained in this section is as follows:

- 2-2 Installation
- 2-3 Operating Controls, Dials, and Terminals
- 2-4 Turning on the Equipment
- 2-5 Continuous Wave Operation
- 2-6 Internal Sine Wave Modulation
- 2-7 External Sine Wave Modulation
- 2-8 Pulse Modulation
- 2-9 Crystal-Controlled Beat-Frequency Calibrator
- 2-10 Signal Generator Loading Considerations

2-2 INSTALLATION

The Model 608D operates from a nominal 115/230-volt, 50 to 400 cps single-phase power source. If the equipment is to be operated from a 230-volt source, the power transformer primary winding must be reconnected as indicated on the schematic diagram. The power cord supplied for connecting the generator to the power source is equipped with a motor-base connector and contains three conductors. The third conductor projects from the cord at each end in the form of a green pigtail lead. This lead is for grounding the signal generator chassis to an external ground. To ground the signal generator chassis connect one pigtail lead under one of the mounting screws for the motor base connector on the instrument chassis. Connect the other pigtail lead to the a-c outlet mounting box.

2-3 OPERATING CONTROLS, DIALS, AND TERMINALS

The front panel operating controls, dials, and terminals for the 608D are listed with their functions in Table 1 and are shown in Fig. 2. A simplified block diagram showing which circuits are affected by various front panel controls is shown in Fig. 3.

2-4 TURNING ON THE EQUIPMENT

CAUTION

Do not obstruct the ventilating louvers on the sides of the instrument cabinet. Safe operating temperature depends on free air flow through these louvers.

To place the signal generator into operation, proceed as follows:

- a. Locate the signal generator near a 115-volt a-c power source.
- b. With power switch in "off" position, connect the power cord to the signal generator and to the power source.
- c. Place the MOD. SELECTOR in the CW position and the OUTPUT LEVEL control to near maximum. Other controls may be set in any position before turning generator on.
- d. Turn power switch to the ON position. The POWER pilot lamp should indicate that power is applied to all circuits of the signal generator.
- e. After approximately 1-minute warm-up, adjust the AMP. TRIMMER for maximum reading and OUTPUT LEVEL control to obtain a SET LEVEL reading on the front panel OUTPUT VOLTS meter.
- f. Allow equipment to heat for 5 minutes before use. If greatest frequency stability is required, allow equipment to heat for 45 minutes.

Table 1. Controls and Terminals

Ref. No. Fig. 1.	Designation	Function
1	Power Receptacle	Receives power from cord supplied. For use on 115-volt, 50 to 400 cycle, single-phase, a-c source.

Table 1. (Continued)

Ref. No. Fig. 1	Designation	Function
2	DC 0,25 AMP (fuse)	Protects the internal d-c power supply against short circuits in the instrument.
3	AC 3 AMP (fuse)	Protects power source and instrument against short circuits.
4	Power Switch	In the ON position all circuits of the signal generator are energized.
5	POWER (pilot lamp)	Pilot lamp that indicates when main circuits are energized.
6	MOD. SELECTOR (switch)	Prepares circuits for desired type of modulation.
7	FREQUENCY RANGE (switch)	Selects frequency range to be used and positions the range pointer on the MEGACYCLES dial.
8	FREQUENCY CONTROL	Selects output frequency in combination with FREQUENCY RANGE switch.
9	MEGACYCLES (dial)	Indicates the frequency of the r-f output signal directly in megacycles.
10	AMP. TRIMMER (control)	Tunes r-f power amplifier circuit to track with oscillator for maximum output as indicated on output meter.
11	OUTPUT LEVEL (control)	Adjusts the r-f power level existing at input to output attenuator.

608D 5/19/55 Serial 192 and above #608D006

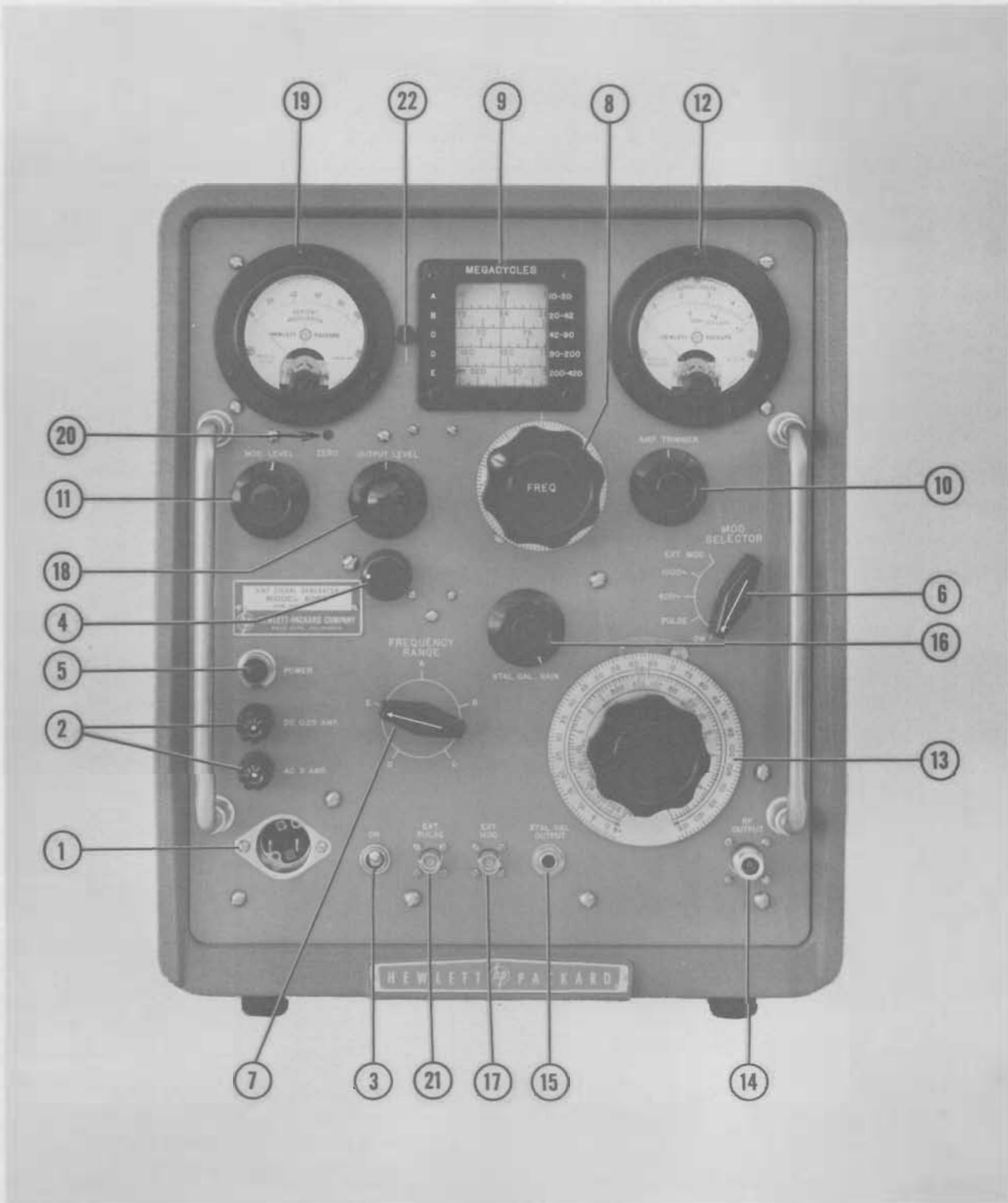

Fig. 2. Model 608D Signal Generator Front Panel Controls

608D 5/19/55 Serial 192 and above #608D0006

Table 1.

Ref. No. Fig. 1.	Designation	Function
12	OUTPUT VOLTS - DBM (meter)	Indicates r-f power level existing at input to output attenuator.
13	Output Attenuator (control)	Selects and indicates the r-f output level in microvolts, millivolts, and decibels.
14	RF OUTPUT (jack)	Output connector for r-f output signal (See CAUTION).
15	XTAL CAL. OUT- PUT (connector)	Output connector to connect earphones to crystal calibrator.
16	XTAL CAL. GAIN (control)	Adjusts loudness of beat frequency signal obtained from XTAL CAL. OUTPUT jack.
17	EXT. MOD. (jack)	Receives sine wave from external source for modulation of r-f output signal.
18	MOD. LEVEL (control)	Adjusts modulation percentage to desired value as indicated on modulation meter.
19	PER CENT MODU- LATION (meter)	Indicates the percentage modulation of the r-f output signal.
20	ZERO	Electrically sets the modulation meter to zero with instrument in operation with no modulation applied.
21	EXT. PULSE (jack)	Receives pulses from external source for modulation of the r-f output signal.
22	CALIBRATION ADJUSTMENT	Positions window hairline to frequency dial.

608D 5/19/55 Serial 192 and above #608D0006

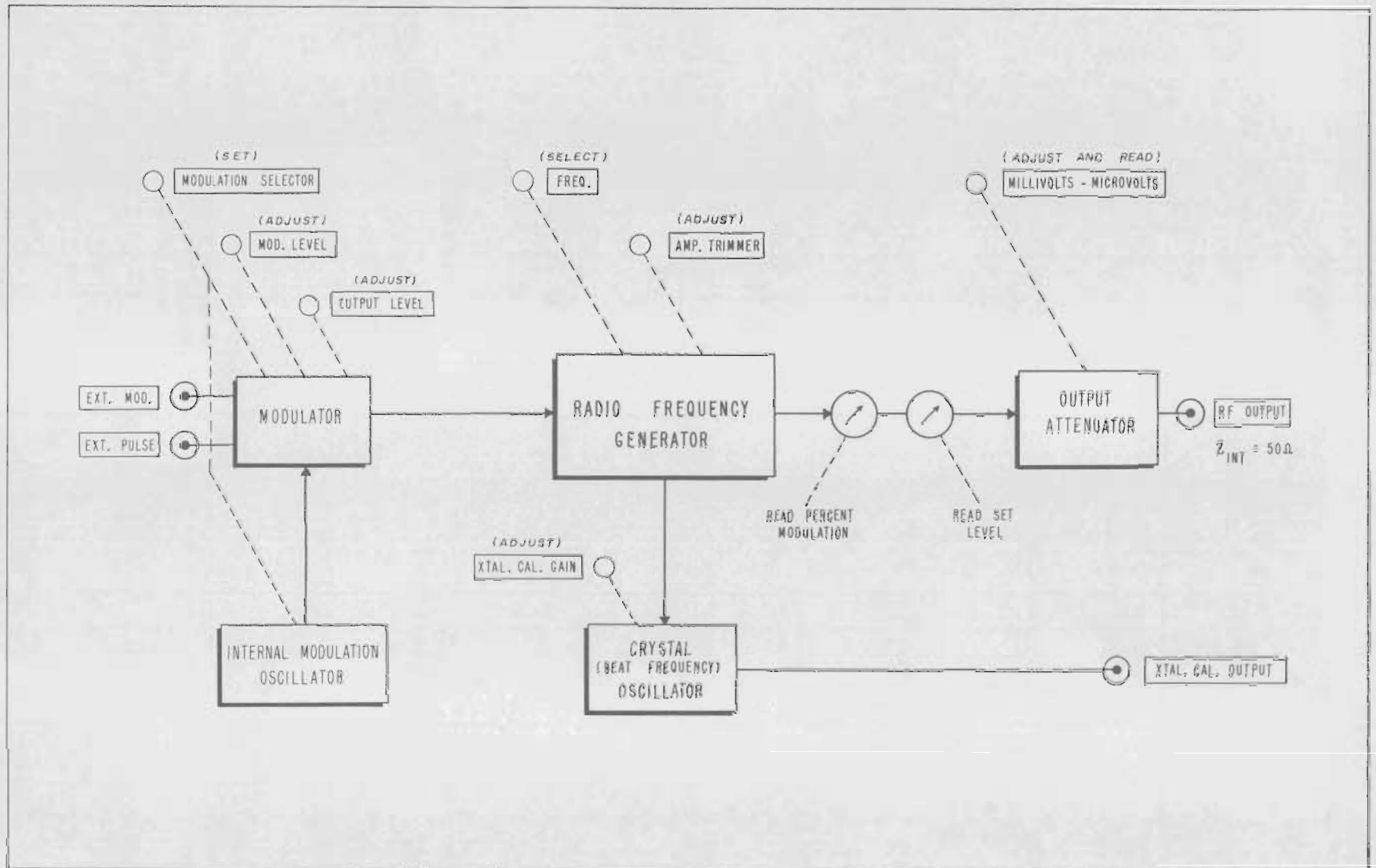

Fig. 3. Diagram Showing Relationships of Front Panel Controls to Major Circuits

CAUTION

Do not connect any source of r-f or d-c power to the RF OUTPUT jack on the Model 608D Signal Generator. To do so will burn out the impedance matching network in the output attenuator and no output will be obtained. Special care must be taken when working with "transceiver" type equipments, such as VHF aircraft equipment, to insure that the transmitter remains inoperative while the signal generator is connected to the equipment antenna.

NOTE

For protection to the output attenuator on the Model 608D Signal Generator, a special fuseholder is available for connection to the RF OUTPUT connector. When using the signal generator for any application where there is the possibility of voltage being applied to the RF OUTPUT jack, this fuse may be used between the output jack and the test cable connecting the signal generator to the external equipment.

2-5 CONTINUOUS WAVE OPERATION

General

For CW operation the 608D supplies a continuous wave output signal with less than 1% harmonic or spurious signals and with less than 0.1% incidental amplitude modulation. Over 1 milliwatt of power can be obtained across an external 50-ohm load with the output level directly indicated to an accuracy of better than ± 1 db for all types of operation (see paragraph 2-10). When set for CW operation, the MOD. LEVEL and XTAL CAL. GAIN controls are inoperative and may be set to any position. The PERCENT MODULATION meter, however, monitors the output signal during all types of operation and may give momentary fluctuations resulting from switching transients.

Step-by-Step Procedure for Obtaining CW Operation

- a. Following the "turning on" procedure described above, set the MOD. SELECTOR to CW.
- b. Select the desired band of frequencies with the FREQUENCY RANGE selector.
- c. Set the MEGACYCLES dial to the desired frequency.
- d. Set the OUTPUT LEVEL control to near maximum.
- e. Adjust the AMP. TRIMMER for maximum output as indicated on OUTPUT VOLTS meter.
- f. Connect the external load to the RF OUTPUT jack on the signal generator. (See preceding CAUTION.)
- g. Set the OUTPUT LEVEL control to obtain a reading at SET LEVEL on the OUTPUT VOLTS meter.
- h. Set the output attenuator for the desired output level as read directly from the output attenuator dial.

2-6 INTERNAL SINE WAVE MODULATION

General

For internal sine wave modulation of the r-f output signal, the 608D supplies the same quality r-f signal as is obtained for CW operation and which may be modulated by either 400- or 1000-cycle internally generated sine waves selected by the MOD. SELECTOR switch. The modulating frequencies are accurate to within $\pm 10\%$, and envelope distortion of the modulated carrier is less than 5% for modulation percentages to 30%. The percent modulation is continuously adjustable from 0 to 95% by the MOD. LEVEL control and is read directly from the PERCENT MODULATION meter to within $\pm 10\%$ of the meter reading from 30 to 95%. Incidental frequency modulation resulting from amplitude modulation of the output signal is held extremely low, being less than 1000 cycles for reasonable modulation percentages. For modulation percentages below 50%, the frequency modulation index will not exceed 1.0. Output frequency and power level are set in the same manner as for CW operation except that the MOD. SELECTOR is set to 400 or 1000.

Step-by-Step Procedure for Obtaining Internal Modulation

- a. Follow complete step-by-step procedure for obtaining CW operation.
- b. Set the MOD. SELECTOR to 400 or 1000 as desired.
- c. Set the MOD. LEVEL control for desired degree of modulation as indicated on the PERCENT MODULATION meter.
- d. Subsequent changes may be made in the frequency dial and output attenuator settings while instrument is being operated with modulation.

NOTE

It may be noticed that when the percent modulation is increased to very high levels there will be a resulting increase in the reading of the OUTPUT VOLTS meter. The OUTPUT LEVEL control should be reset to maintain a reading at SET LEVEL on the OUTPUT VOLTS meter.

2-7 EXTERNAL SINE WAVE MODULATION

General

An external signal source generating frequencies from 20 to above 100,000 cycles per second with an amplitude of approximately .5 volt may be used to modulate the r-f output signal from the signal generator. The modulation is of the same high quality as that obtained with internal modulation. The modulating signal is applied through an appropriate cable to the EXT. MOD. jack on the front panel. The degree of modulation is continuously adjustable by means of the MOD. LEVEL control and is indicated directly on the front panel PERCENT MODULATION meter. Being a peak reading device, the modulation meter also indicates the modulation percentage of complex waveforms (square waves, sawtooth waves, etc.) that are applied to the EXT. MOD. jack. The input impedance at the EXT. MOD. jack is approximately 20,000 ohms.

Step-by-Step Procedure for Obtaining External Modulation

- a. Follow complete step-by-step procedure for obtaining CW operation.

- b. Set MOD. SELECTOR to EXT. MOD. position.
- c. Connect modulating source to EXT. MOD. jack.
- d. Set MOD. LEVEL control for desired degree of modulation as read on the PERCENT MODULATION meter.
- e. Subsequent changes may be made in frequency dial and output attenuator settings while the instrument is being operated with modulation.

NOTE

It may be noticed that when the percent modulation is increased to very high levels there will be a resulting increase in the reading of the OUTPUT VOLTS meter. The OUTPUT LEVEL control should be reset to maintain a reading at SET LEVEL on the OUTPUT VOLTS meter.

2-8 PULSE MODULATION

General

An external pulser generating positive pulses above 5 volts in amplitude may be used to modulate the r-f output signal from the 608D Signal Generator. The resultant r-f output pulse from the signal generator is of good quality at r-f frequencies above 100 megacycles, is free of transients, and has low residual signal between pulses. For pulse operation the signal generator produces essentially no r-f output signal until an external positive pulse is applied to the EXT. PULSE jack. The amplitude of the modulation pulse is not adjustable by the MOD. LEVEL control; however, the indications on the PERCENT MODULATION meter cannot be used with signals supplied to the EXT. PULSE jack. Any pulse above 5 volts amplitude will 100% modulate the r-f output signal, the peak level of the r-f pulse being within 1 db of the CW level established by the same settings of the OUTPUT LEVEL control and the output attenuator.

Step-by-Step Procedure for Obtaining Pulse-Modulated Output

- a. Follow complete step-by-step procedure for obtaining CW operation.

- b. Set the MOD, SELECTOR to the PULSE position.
- c. Connect modulating source to EXT, PULSE jack on front panel.

2-9 CRYSTAL-CONTROLLED BEAT-FREQUENCY CALIBRATOR

The frequency (MEGACYCLES) dial in the 608D Signal Generator is calibrated to be accurate within 1.0%. To obtain higher accuracy, a crystal-controlled calibrator has been included which provides the operator with a means of setting the MEGACYCLES dial calibration "on frequency" at any multiple of 5 megacycles over the entire frequency range of the signal generator. Basically, the calibrator provides a 5-megacycle signal accurate to $\pm 0.01\%$ which, by heterodyning with the output frequency, produces a beat-frequency check point at every integral multiple of 5 megacycles. These check points appear as audible beats which can be heard by connecting a common headset to the XTAL CAL. OUTPUT jack, with a volume control (XTAL CAL. GAIN) provided for adjusting the sound level. An adjustment (knurled knob left of MEGACYCLES dial) is provided which adjusts the position of the index window a small amount each side of center and is used to set the MEGACYCLES dial "on frequency" at the selected check point. For best accuracy the MEGACYCLES dial should be set "on frequency" on a calibration line nearest to the frequency to be used.

2-10 SIGNAL GENERATOR LOADING CONSIDERATIONS

When using the Model 608D, the external load connected to the instrument should be 50 ohms resistive for best accuracy of indicated output power. The output attenuator dial has been calibrated by using a "flat" load of 50 ohms. The internal impedance of the generator is sufficiently close to 50 ohms so that in the worst case a VSWR of only 1.2 (SWR of 1.6 db) exists when the generator is compared with 50 ohms. Error in power level indication with this magnitude of VSWR will have no important effect on the accuracy of the output attenuator dial. However, if the value of the load is not known and if best accuracy in measurements is desired, it is necessary that the standing wave ratio in the line to the load be minimized.

Table 2 shows the calculated power loss when the load on the signal generator causes a voltage standing ratio of the magnitude shown. The VSWR values shown are a comparison between a load and a 50-ohm transmission line. The minimum loss figures are based on a mismatch of 1.2 VSWR between the signal generator

and transmission line. Mismatches causing the voltage standing wave ratios given in the left-hand column will give power losses somewhere between the limits shown in the remaining two columns. The maximum loss shown is the total loss from the maximum power available from the generator for a given setting of the output attenuator and includes the possible generator VSWR of 1.2. The data does not allow for losses in the transmission line to the load, for in most cases such losses are sufficiently small so that they are not of importance.

It will be seen that when the load is matched to the transmission line (VSWR = 1.0) the loss from the maximum power available from the signal generator is approximately 0.06 db in the worst case. Although the losses as shown in db do not consist of large numerical values, it should be noted that they may represent a considerable change in the voltage calibration of the output attenuator dial so far as the voltage impressed across the external load is concerned.

Table 2

VSWR in 50-ohm Line	Min. Power Loss	Max. Power Loss
1.0	.06 db	.06 db
1.5	.08 db	.37 db
2.0	.3 db	.85 db
2.5	.6 db	1.3 db
3.0	.9 db	1.7 db
4.0	1.5 db	2.4 db
5.0	2. db	3.1 db

In most cases when making measurements on receivers designed to work from a 50-ohm line and antenna, the standing wave ratio in the line from the signal generator to the receiver is not significant. The reason for this is that any power reflected from the receiver back towards the generator represents a deficiency in receiver design, and the amount of power lost in such cases is considered as a loss subtractive from the gain of the receiver. A sometimes overlooked factor which contributes error in high-frequency measurements is the improper assembly of coaxial connectors. A standing wave ratio of several db with attendant error can often be attributed to this cause.

2-11 FINE FREQ. ADJUST. CONTROL

Model 608D Signal Generators with serials 104 and above are equipped with a short range incremental tuning device for making extremely small changes in the output signal frequency. The fine frequency tuner is operated from the front panel by a small knob to the left of the main FREQ. control knob. This control adds a very small capacity to the existing capacity in the oscillator tank; the change occurring over 180° rotation of the knob. When the dot points to the left, the vernier capacity is maximum; when the dot points to the right, the capacity is minimum. The main frequency dial calibration is most accurate when the dot on the knob is aligned with the dot on the front panel.

When the signal generator is operated at the high ends of the frequency ranges and when the finest possible frequency control is required, adjust the main frequency control very closely to the desired frequency with the vernier set slightly above minimum capacity, i. e., dot pointing to right; then adjust the vernier control for the exact desired frequency. When operating at the low ends of the frequency ranges the effectiveness of the vernier is decreased and must be used at near maximum capacity.

The accompanying figure shows the vernier device as it is mounted within the oscillator tuning compartment of the r-f generator assembly. The fine frequency tuner consists of a small metal disk mounted off center at the end of a bakelite control shaft. The shaft is mounted level with the oscillator tuning capacitor about $1/2$ -inch away. As the shaft is turned, the disk moves closer or farther from the tuning capacitor to increase and decrease the capacity in the tuned circuit.

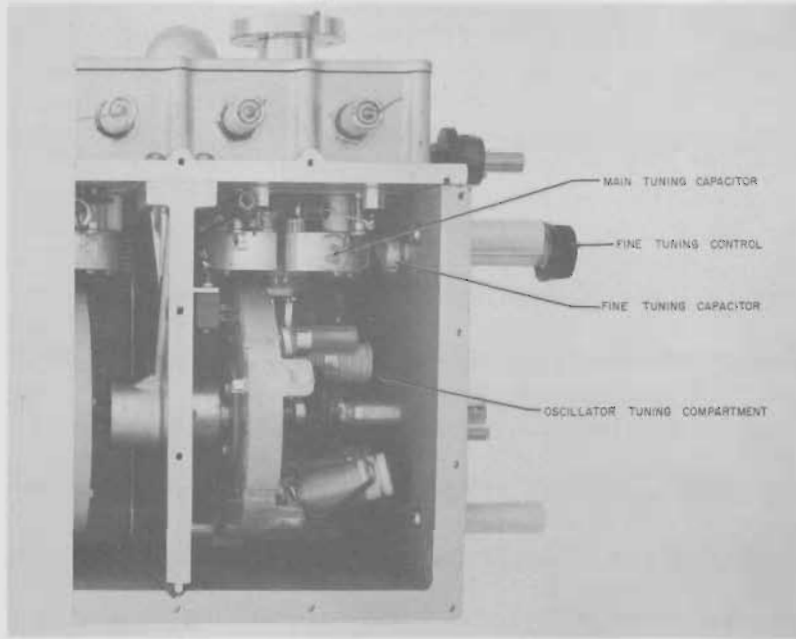

R-F Oscillator Compartment Showing
Fine Frequency Tuning Control

SECTION III
THEORY OF OPERATION

3-1 GENERAL

The electrical circuits of the Model 608D Signal Generator are divided into the sections shown in the block diagram in Figure 4, plus a power supply which is not shown. Briefly, the operation of the various sections is as follows:

- a. The radio frequency oscillator generates the r-f signal which is fed through a buffer and power amplifier to the output jack of the signal generator. The oscillator is of the Colpitts type and provides a continuously variable sine wave signal of high stability.
- b. The buffer isolates the oscillator from the power amplifier and minimizes interaction between the two circuits.
- c. The radio frequency power amplifier receives both the r-f and modulation signals and amplifies the r-f energy for application to the output attenuator. The r-f amplifier also receives variable bias from the modulator which permits adjustment of the power level fed to the output attenuator.
- d. The output power monitor samples the r-f energy fed to the output attenuator and indicates the power and voltage level on a front panel meter.
- e. The output attenuator obtains monitored r-f energy from the power amplifier, applies the selected degree of attenuation, and conducts the energy to the front panel output jack.
- f. The beat frequency calibrator generates harmonics of the 5 mc signal from the crystal and mixes these harmonics with r-f energy coupled from the r-f amplifier. The resultant beat frequency signal is amplified and fed to the front panel earphone jack.
- g. The internal modulation oscillator generates either a 400 or 1000 cycle-per-second sine wave for application to the modulation system.
- h. The modulator receives all signals for application to the r-f power amplifier and also supplies variable bias to the r-f amplifier for control of the r-f output level.

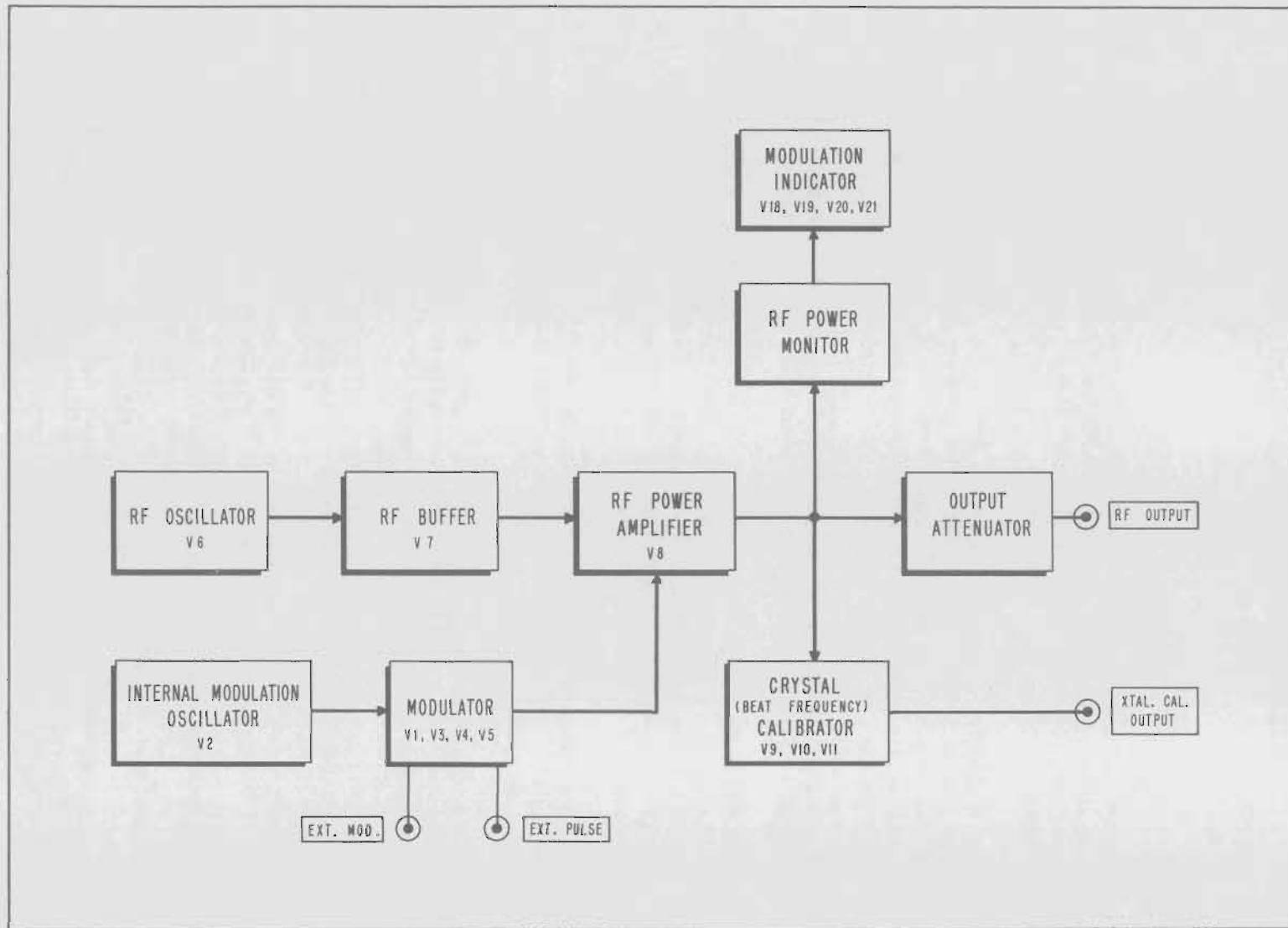

Fig. 4. Block Diagram for Signal Generator 608D

- i. The modulation-measuring circuits receive detected modulation from the r-f power monitor, amplify and rectify it, and indicate the modulation percentage directly on a front panel meter.

3-2 RADIO FREQUENCY OSCILLATOR

The radio frequency oscillator generates a sine wave signal from 10 to 420 megacycles in five frequency bands, each band having approximately a 2:1 frequency range. A type 5675 "pencil" triode tube is used in a Colpitts circuit tuned by a precision split-stator capacitor (plate meshing type) and five separate r-f transformers, L1 through L5. The tuning capacitor, which is specially constructed for high stability and resetability, consists of two stator sections connecting to the grid and plate of the oscillator tube and a floating rotor which meshes equally between the two stators. The tuning capacitor assembly, mounted inside and near the top of the tuning compartment in the r-f generator housing, is driven by a ball bearing mounted worm drive through the top of the housing casting.

The tuned coils consist of precision-wound, plated wire on 5/8-inch diameter ceramic forms on the A, B, and C bands and of silver-plated, Nilvar loops on the D and E bands. The five inductors are mounted on a revolving turret actuated by the FREQUENCY RANGE selector. As the turret is rotated, the desired coil is positioned in the tuned circuit just below the oscillator tube and tuning capacitor, connections being made through large silver-plated contacts mounted directly on the bottoms of the two stators of the tuning capacitor. Both ends of the tuning inductor and capacitor are at r-f and d-c potential, with no part of this circuit grounded.

The oscillator tube, V6, is operated across the -165-volt and +225-volt supplies with considerable series resistance to limit the maximum plate current that can flow. The plate is series-fed through a 3000-ohm resistor, R45, which also serves to isolate the tuned circuit from r-f ground at C15, while the cathode is returned to -165 volts through R42 and R43. Cathode by-pass capacitor C25 is actually part of the tube mounting plate and is not visible when the plate is in position. R42 prevents resonance in the cathode lead; R43 in conjunction with R45 limits the maximum plate current that can flow through V6. Bias for the control grid is obtained across grid leak resistor R44, which under usual conditions develops approximately 70 volts of bias. C16 couples the tuning coil to the grid, the drive being determined by the ratio of grid-plate to grid-cathode impedance. These impedances consist partly of inter-electrode capacity, shown as dotted components

in the partial schematic diagram, and largely of lumped constants in the tuned circuit. The grid-plate capacity is shunted by the tuned circuit and a small trimmer capacitor C18, while the grid-cathode capacity is shunted by trimmer capacitor C59. C18 sets the minimum capacity of the tuned circuit and is used to adjust the high frequency limit of all bands when the oscillator tube is replaced. C59 is an additional adjustment usually set for minimum capacity and requiring no readjustment. This capacitor has minor effect on the grid drive at the high frequency ends of the bands and is usually set for maximum drive. The inductances of the tuned inductors is variable over a small range by adjusting a single shorting turn on each coil for the A, B, and C bands and by adjusting the size of the single loops for the D and E bands. These adjustments are used at the factory to set the low frequency limit of each frequency band.

Heater voltage for the oscillator tube is obtained from a multivibrator operating on regulated voltage which supplies very stable heater power. All power to the oscillator tube is brought through the housing by special filters having very high attenuation of radio frequencies to prevent conduction of the r-f energy outside the instrument. The tuned circuits for the oscillator are located in a lower front compartment, the other circuits in a tube compartment above. An inside view of the r-f generator assembly is shown in Figure 14. The oscillator tube is mounted through the top of the tuning compartment so that the grid and plate elements project through the top plate into the tuning compartment, while the heater and cathode elements remain above the top plate. Mounting facilities are contained in the upper compartment, and the tube may be replaced from the upper compartment without entering the tuning compartment.

3-3 RADIO FREQUENCY BUFFER

The loosely-coupled secondary winding on each of the oscillator coils couples r-f energy from the oscillator through a coaxial cable to the buffer stage located in the tube compartment in the top of the r-f generator housing. The buffer tube, V7, is a type 6BC4 miniature triode connected as an untuned, grounded-grid amplifier and serves to isolate the oscillator circuit from the effects of the modulation signal at the cathode of the power amplifier. The use of the buffer reduces incidental frequency modulation to an extremely small value.

Although the buffer tube V7 utilizes a large cathode resistor (R116, 7500 ohms), it operates with practically zero bias and relatively high plate current. R116 holds plate current constant for a wide range of tube characteristics and in conjunction with R47, a dropping

resistor in the plate supply lead, serves to limit plate current to safe values. Resistors R46, R108, R109, R110, and R112, which are mounted on the coils for each band, damp unwanted resonance in the cathode lead. Resistors R111 and R113 shunting the A and B band coupling coils limit the somewhat greater r-f drive from these coils. The plate of the buffer is coupled to the cathode of the r-f amplifier through a wide-band, coupling network consisting of coil L8 with damping resistor R13, series coil L9 with blocking capacitor C56, and shunt peaking coils L10 and L11. Resistors shunting the peaking coils are used as the forms for the windings. The resistor values are selected to damp the resonant peaks of the coils.

3-4 RADIO FREQUENCY POWER AMPLIFIER

The radio frequency power amplifier, V8, amplifies the r-f energy received from the buffer for application to the r-f output attenuator. The circuit consists of a 5876 "pencil" triode connected as a grounded-grid, cathode-modulated amplifier. The plate circuit of the amplifier is tuned in the same manner as the oscillator, with a similar split-stator capacitor and five untapped coils mounted on a revolving turret. The amplifier tuning capacitor is ganged with the oscillator capacitor by a double-ended worm drive. The amplifier capacitor is provided with a mechanical linkage, controlled from the front panel, to shift the rotor plates from their normal tracking position with respect to the oscillator. This control allows the amplifier tuning to be trimmed for maximum output at all frequencies.

The coil mounting turret is also ganged with that of the oscillator. Tuned coils are wound with copper wire on teflon forms, and the coil in use is so located to be inductively coupled to the output attenuator probe.

The power amplifier tube is operated across the -165 and +225-volt supplies. The plate is series fed from the 225-volt supply through decoupling filter R57 and C33. The cathode is returned through a portion of the wide-band coupling filter and resistors R35 and R36 to the -165-volt supply. R36 matches the higher impedance of the cathode circuit of V5 to the lower impedance of the cathode circuit of V8, while R35 is the cathode bias-developing resistor. R35 is also the cathode load resistor for control tube V5, and the bias voltage developed across R35 is largely controlled by the current established in V5. The modulating signal is also developed across R35 and with the bias voltage is fed to the cathode of V8. Crystal diode CR7, connected between the cathode return circuit and ground, limits the lowest potential to which the cathode can be driven. This arrangement protects V8 from the effects of

any negative switching transients which might be applied to its cathode. The plate tank is tuned by C17B. C32, a small trimmer capacitor across C17B, sets the minimum capacity and is provided for adjusting the tracking of the highest frequency band so that minimum operation of the AMP TRIMMER control is required. The inductances of the tuned coils can be adjusted over a small range by means of metal sleeves between the cores and coils on the B, C, and D bands and by altering the winding shape and size on the A and E bands. These adjustments are set at the factory to track the low frequency end of each band with the frequency of the oscillator.

Heater supply voltage for the r-f amplifier, buffer and oscillator is obtained from the regulated heater supply multivibrator. Filter FL9 in the heater circuit reduces incidental frequency modulation by preventing leakage of modulating signals between the heaters of the oscillator and amplifier tubes. The tuned circuits of the r-f amplifier are contained in the rear compartment of the r-f generator housing. The other amplifier circuits are located in the compartment above. The amplifier tube is mounted through the top of the tuning compartment so that the plate element projects through the top plate into the tuning compartment. The heater and cathode elements are in the upper compartment and the tube may be replaced without entering the tuning compartment.

3-5 OUTPUT ATTENUATOR AND R-F POWER MONITOR

To extract power from the r-f power amplifier a piston attenuator is used. The housing for the attenuator projects through the rear of the r-f generator housing and terminates, open-ended, close to the r-f amplifier plate circuit inductor. A single-turn, pickup loop at the end of the attenuator probe couples energy to an impedance-matching network, C37, R58, and R59, mounted on the face of the probe and through a section of double-shielded coaxial cable to the RF OUTPUT jack. Adjustable capacitor C37 is actually a movable slug in the probe body. It allows minor adjustment of the internal impedance of the generator so that a minimum standing wave ratio is obtained when the output jack is terminated in a 50-ohm load.

The r-f power level which is fed to the attenuator is sampled and continuously monitored by an antenna (two parallel wires crossing the open end of the attenuator housing) connected to a small detector assembly mounted under the housing inside the r-f amplifier tuning compartment. This power level is indicated in both volts and decibels, over a limited range, on the front panel power level meter. A calibration mark on the meter marked SET LEVEL establishes a correct amount of power fed into the attenuator

housing for direct reading of the output attenuator dial calibrations.

Radio frequency energy is coupled from the power monitoring antenna to a detector through L17, a small coil used to adjust the frequency response of the detector circuit. Crystal diode CR2 with return resistor R60 rectifies the radio frequency energy and produces a d-c voltage equal to half the peak-to-peak r-f voltage. C38 and filter FL8 remove the remaining r-f component and couple the d-c voltage to a compensating network, CR3 and R61. R119 flattens the frequency response of the circuit. FL8 is specially designed to attenuate all radio frequencies above approximately 3 megacycles and to pass all frequencies below that frequency with little or no attenuation. CR3 corrects for non-linearities in detector CR2 when the r-f signal level is low and detection takes place in the non-linear region of the diode. The degree of compensation is set by potentiometer R61 and is adjusted to obtain accurate down-scale readings on the front panel power level meter. M1 is calibrated to indicate the rms value of the r-f output signal. Potentiometer R62 adjusts the sensitivity of the meter and is set at the factory with accurate vhf power measuring equipment.

3-6 XTAL (BEAT FREQUENCY) CALIBRATOR

The calibrator consists of a crystal-controlled oscillator and detector located in the r-f amplifier tuning compartment and an 80 db resistance-coupled amplifier located on the right side chassis of the instrument.

The crystal oscillator uses a type 6AU6 miniature pentode connected as an electron coupled oscillator, having both the plate and screen circuits tuned to the crystal frequency of 5 megacycles. Limited adjustment of the crystal frequency is provided by trimmer C23 connected across the crystal. The calibrator signal is coupled from the plate of the oscillator through blocking capacitor C24 to the cathode of mixing diode CR1. The signal from the r-f power amplifier is inductively coupled to the anode of the mixing diode by running the anode lead of the diode close to the r-f amplifier circuits. Harmonics of the calibrator are generated in the crystal and mixed with the r-f signal to produce beat frequency signals across R50.

Beat frequency signals from the mixing diode are taken through r-f filter FL7 in the r-f generator housing to a conventional three-stage resistance-coupled amplifier consisting of V10 and V11, high- μ twin triodes connected in cascade and located on the rear chassis. Only one half of V10 is used, the remaining half being grounded. Due to the extremely high gain (approximately 80 db) of the amplifier, grounding of the input circuits is extremely

critical. The load resistor (R50) for mixer diode CR1 and the cathode and grid return resistor (R51) for V10 are not grounded near the tube socket but are connected to the shield of the input cable which in turn is grounded at the r-f generator housing, as shown on the schematic diagram. Potentiometer R56 in the grid circuit of the last amplifier stage controls the volume of the beat frequency output signal. The signal from output stage is coupled through a 600-ohm line matching transformer T3 to the front panel EXT CAL. OUTPUT jack.

3-7 MODULATOR SECTION

The purpose of the modulator section is threefold: to generate 400- and 1000-cycle sine waves for internal modulation of the generator; to amplify all modulation signals for application to the r-f power amplifier; to control the power level obtained from the r-f amplifier for all types of operation by varying the bias on the r-f amplifier tube. The modulator consists of a resistance-tuned oscillator, V2, a limiter and single-stage video amplifier, V1 and V3, and a cathode follower output stage and output level control tube, V4 and V5. The modulator circuits are located along the upper portion of the right side chassis; the oscillator on the bottom portion.

The modulation oscillator is a resistance-tuned sine wave generator of the Wein Bridge type. Basically, the circuit consists of a two-stage resistance-coupled amplifier which is caused to oscillate by the use of a frequency-selective positive feedback circuit. At the resonant frequency there is no phase shift in the positive feedback circuit, so that a voltage of the resonant frequency on the grid of the first tube is reinforced by the output of the second tube and oscillation occurs. The two different frequencies of operation are obtained by switching two different sets of resistors, R3 - R5 and R4 - R6, into the positive feedback network when the MOD. SELECTOR is turned from 400 λ to 1000 λ . Precision resistors having good stability are used in the tuned circuit. Capacitors C2, C3, and C4 comprise the remainder of the tuned circuit. In addition to the positive feedback network, a negative feedback circuit is also used to stabilize the oscillator, reduce distortion, and to maintain a constant output level. This circuit consists of a 3-watt lamp, I1, used as a thermal resistance element having a positive temperature coefficient, composition resistor R8 and amplitude adjusting potentiometer R7. The high positive temperature coefficient of the lamp provides automatic amplitude control of the signal, for if the amplitude of oscillation tends to increase, the current through the lamp tends to increase, thereby increasing the lamp's resistance. Consequently, the negative feedback tends to increase and amplitude of oscillation is maintained constant. The amplifier portion consists of two medium- μ triodes, V2A and B,

in a conventional resistance-coupled circuit with the output voltage being obtained from the cathode of the second stage. Although heater voltage is applied to the oscillator at all times the instrument is in operation, plate voltage is applied to V2 only when the MOD, SELECTOR switch is in the 400- or 1000-cycle position.

The sine wave signal from the modulation oscillator or from an external signal source is coupled through the MOD, LEVEL control to the limiter tube V1, a 5670 twin triode, then to video amplifier V3, a type 6CL6 pentode. The purpose of V1 is to limit the peak amplitude of modulating pulses, since for pulse modulation the input signal is fed directly to the grid of the limiting amplifier without passing through the MOD, LEVEL control. The limiting action of V1 begins at approximately +2 volts peak which is considerably more than that required for 100% modulation of the output signal. Consequently, signals producing less than 100% modulation pass through the limiter unchanged. Limiting effectively squares the top of an incoming positive waveform above approximately 2 volts without affecting its rise and fall or introducing transients. The uninverted signal from amplitude limiter V1 is then amplified approximately 18 db by V3, a resistance-coupled 6CL6 pentode voltage amplifier, and coupled to output cathode follower V4.

From the limiter and amplifier, the modulating signal is fed to output cathode follower V4, a triode-connected type 6CL6 pentode. For sine wave modulation the signal from the cathode of V4 is coupled through switches S1E and S1F to the grid of the output level control tube V5 and superimposed on the variable bias voltage. The cathodes of both V5 and the r-f power amplifier V8 are connected together and returned to the -160-volt supply through resistor R35. Any signal placed on the grid of V5 is therefore directly coupled from the cathode of V5 to the cathode of the r-f power amplifier V8. The d-c voltage level established at the cathodes of the two tubes is determined largely by the current flowing in V5. The current in V5 is controlled by the dual potentiometer voltage divider, R34, R37, and R40, in the grid circuit. The cathode bias for V8, and consequently the r-f output power, is varied by front panel output level potentiometers R37A and R37B.

For pulse modulation the cathode of V4 is connected by the MOD, SELECTOR switch directly to the cathode of V5. The additional current drawn by V4 through common cathode resistor R35 produces a sufficiently high bias to cut off the r-f amplifier and reduce the r-f output to zero. The modulating pulses are not applied to the grid of V5, and it now serves only to control the peak level of the r-f output pulse. Negative modulating pulses (the positive input pulse having been inverted in V3) at the grid of V4 cut off V4 and allow the cathode potential to return to the level set by V5

which establishes an r-f output level equal to the CW level as indicated on the output level meter. An r-f output pulse having an envelope shaped like the modulating pulse is then formed.

3-8 MODULATION-MEASURING CIRCUITS

The modulation-measuring circuits in the 608D indicate any modulation of the r-f output signal between 0 and 100% to an accuracy of $\pm 10\%$ or better. These circuits consist of a stabilized wide-band amplifier and a bridge-type metering circuit. The measuring circuit reads the peak value of the rectified modulation signal and is accurate for all waveforms. The meter is calibrated to indicate the percent modulation of a given amount of r-f carrier power. The amount is established by SET LEVEL on the output level meter and is accurate for all settings of the output attenuator.

The circuit diagram for the stabilized amplifier, consists of two conventional resistance-coupled type 6AH6 pentodes, V18 and V19. The circuit is stabilized by negative feedback and provides approximately 22 db gain to approximately 2 megacycles. The feedback loop covers both stages, the feedback signal being coupled from the plate of the second stage through dropping resistor R99 and blocking capacitor C55 to the cathode of the first stage. The circuit for the bridge consists of diode rectifier V20 and twin-triode V21, the two triodes constituting two legs of the meter bridge. With no modulation signal applied to the amplifier, the steady-state d-c potential at the plate of amplifier V19 is coupled to the grids of both triodes of V21. With equal current flowing in the two sides of the bridge, the bridge is balanced and the meter reads zero. Potentiometer R106 is a front panel zero adjustment of the bridge that provides for variations in tube and component values.

A modulation signal from amplifier V19 is rectified by diode V20, and the peak value of the rectified voltage is applied to the triode in one leg of the bridge, unbalancing the bridge and causing the meter to read upscale. The triode in the other leg of the bridge is unaffected by the modulation signal as the signal is filtered out by resistor R101 and by-pass capacitor C58. Potentiometer R104 sets the sensitivity of the meter and is adjusted for correct calibration of the meter.

3-9 POWER SUPPLY

The power supply for the signal generator consists of two electronically regulated high voltage supplies, one providing -165 volts d-c, the other providing +225 volts d-c, with the chassis at

zero potential. Each regulator is supplied from a full-wave bridge-type selenium rectifier with a separate high voltage winding on the power transformer. The power transformer also supplies a-c voltage for all electron tube heaters except the r-f oscillator and power amplifier. The primary winding of T1 is divided into two parts and may be operated in series for 230-volt lines or in parallel for 115-volt lines. The output of each regulated supply is adjustable by screwdriver adjusted potentiometers R80 and R71 on the rear instrument chassis. The +225-volt supply uses the -165 supply for a reference voltage; consequently, a change in the -165 volts also affects the output from the +225-volt supply.

Since the two regulated power supplies are identical in operation, only the -165-volt supply will be discussed. V14, V15, and V16 constitute the voltage regulator circuit for the -165-volt supply. V15 is a constant-voltage tube which provides a reference bias for voltage amplifier V14. V16A operates as the regulator tube (or variable resistor) controlled by the voltage at the grid of V14. If the regulated output from the cathode of V16A tends to increase, the voltage at the grid of V14 tends to increase, causing V14 to draw more current. This lowers the plate voltage of V14 and consequently the grid voltage of V16A, resulting in a greater plate resistance for V16A. The greater plate resistance causes a greater voltage drop across V16A, instantaneously compensating for the increased voltage at its cathode and resulting in a substantially constant voltage output.

If the regulated output tends to decrease, the reverse of the above action occurs, also tending to maintain the cathode voltage constant. Ripple in the output voltage is coupled to the grid of V14 by capacitor C44, while slower variations in the d-c level are fed to the grid of V14 through voltage divider R79, R80, and R81. The bias for V14, and thus the output voltage level from V16A, is determined by the setting of R80.

The operation of the +225-volt supply is identical; but due to additional current required (approximately 150 ma), three regulator tubes (V13A and B, V16B) must be used in parallel. The reference voltage for the +225-volt supply is obtained directly from the -165-volt supply.

3-10 HEATER SUPPLY MULTIVIBRATOR

To provide constant heater voltage to radio frequency tubes V6, V7, and V8, a free-running multivibrator operating on the +225-volt regulated supply is utilized. The multivibrator develops square waves that are substantially constant in amplitude because the plate voltage excursion is limited by the 225-volt supply and

the maximum conductivity of the tube. The type 5687 has sufficient conductivity to cause the plate voltage to fall to approximately 25 volts during the negative half cycle. The multivibrator, which operates without bias, is grid-plate coupled and produces symmetrical waves. Transformer T2 couples the output of the multivibrator to heater circuits within the r-f generator housing. Potentiometer R87 is used to adjust the plate voltage of V17 and thereby acts to control the applied filament voltage for V6, V7, and V8. Resistors R84 and R85, in the grid circuit of the two triodes, prevent grid loading of the opposite plate circuits while the grid is in the positive part of its cycle; R83 and R86 are the grid return resistors.

SECTION IV
MAINTENANCE

4-1 INTRODUCTION

Section IV contains instructions for preventive maintenance, trouble localization, tube replacement procedures, and internal adjustments in the Model 608D Signal Generator. To assist with servicing the signal generator, a trouble shooting chart and circuit-tracing block diagram are also included. At the end of this section will be found additional locating illustrations, tube socket voltage and resistance diagrams, and the schematic diagram for the complete equipment. The following information can be found in this section:

- 4-2 Cabinet Removal
- 4-3 Periodic Checks and Routine Care
- 4-4 Localizing Trouble
- 4-5 Power Supply Trouble Shooting and Adjustment
- 4-6 System Analysis Check Chart
- 4-7 Replacement of Electron Tubes
- 4-8 Radio Frequency Oscillator Tube Replacement
- 4-9 Radio Frequency Amplifier and Buffer Tube Replacement
- 4-10 Xtal Frequency Oscillator Tube or Crystal Replacement
- 4-11 Replacement of Electron Tubes Within the Crystal Power Supplies
- 4-12 Attenuator Probe Replacement
- 4-13 Replacement of Lamp II
- 4-14 Calibration of the Percent Modulation Meter
- 4-15 Output Volts Meter Calibration and R-F Power Monitor Service
- 4-16 Repairing the Calibrator Oscillator
- 4-17 Trouble Shooting Chart

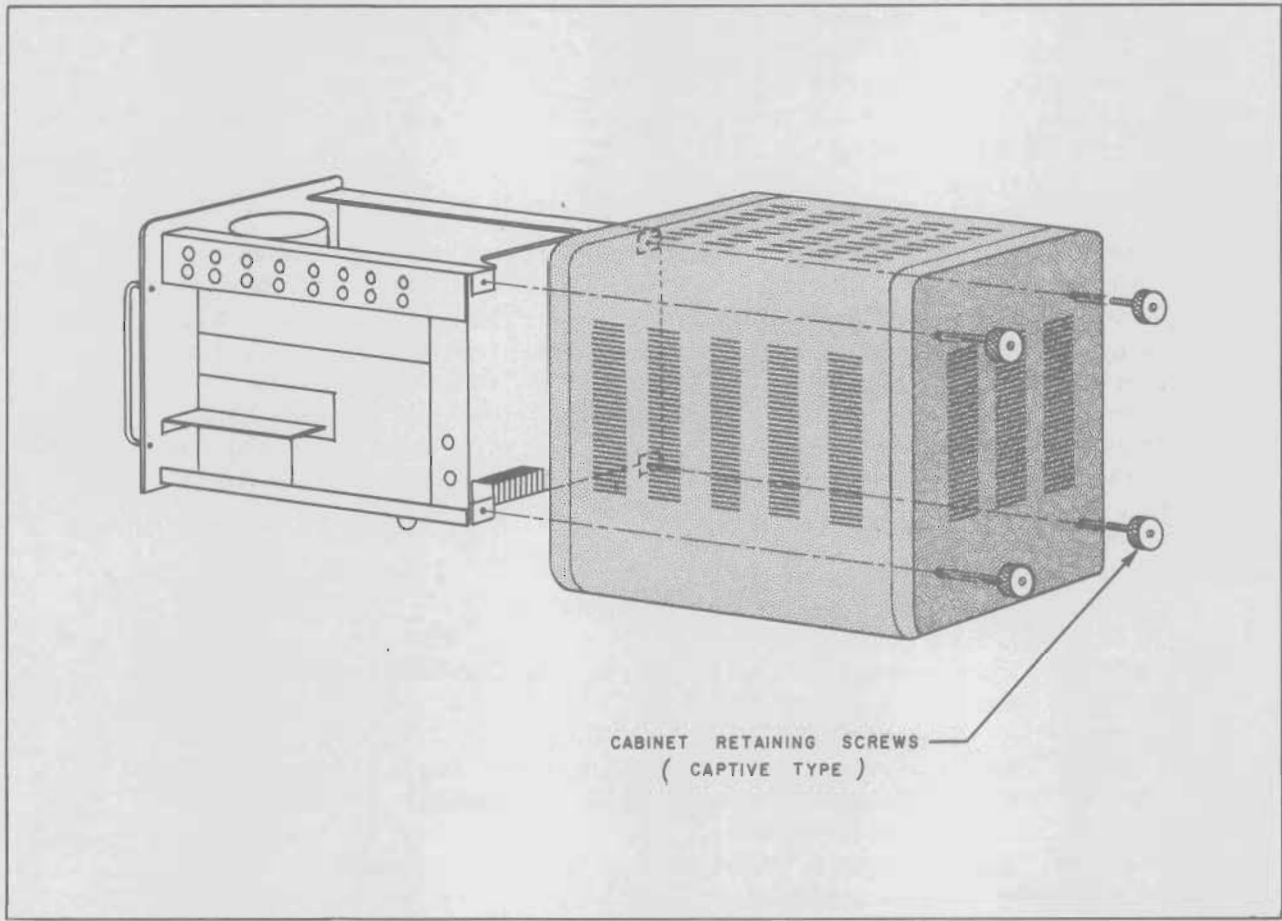

Fig. 5. Cabinet Removal Diagram

4-2 CABINET REMOVAL (Figure 5)

To remove the instrument chassis from the cabinet, loosen the four captive screws on the rear of the cabinet and pull the instrument from its cabinet by the guard-rail handles. The rear of the instrument chassis is supported on steel rollers and should move freely from the cabinet.

4-3 PERIODIC CHECKS AND ROUTINE CARE

Preventive Maintenance

Reasonable care in transporting, handling, and operating the 608D Signal Generator will help to prolong its useful life and minimize trouble. No special checks are required other than a general alertness for the effects of misuse, loose controls, condition of cables and connectors, and possible damage that may be evident in its general appearance. A limited but useful operational check may be performed without the use of external equipment by operating the equipment as instructed in paragraph 2-6, indications of normal operation being read from the two front panel meters. If the equipment has been subjected to unusual conditions - excessive moisture, dust, heat, vibration, etc. - it is suggested that the instrument be removed from the cabinet and inspected for dirt or moisture accumulation, loosened components, or any possible sign of damage. Forced air under medium pressure is recommended for dusting and drying, although care must be taken not to vary the settings of the internal adjustment potentiometers and capacitors during the process. When tightening nuts and screws, various degrees of pressure are required depending on the strength of the material and weight which is supported. Avoid overtightening.

Lubrication

The 608D is thoroughly lubricated at the factory, and it is not to be expected that subsequent lubrication will be necessary during the first year of use. The gears in the r-f generator housing operate at slow speeds and transmit negligible power. Fully shielded ball bearings are used in many applications and require no subsequent attention. Ball bearings that are not fully shielded require only light machine oil. If cleaning and relubrication are needed after prolonged use of the instrument, excessive dust accumulation, or drying of lubricant, reference to the following chart and Figures 6 and 10 will assist with renewing the lubricants at various points on the r-f generator assembly. The two worm gears used in the tuning capacitor drive are lubricated with a mixture of 9 parts of Lubriplate grease #2 and 1 part Molycote. All remaining

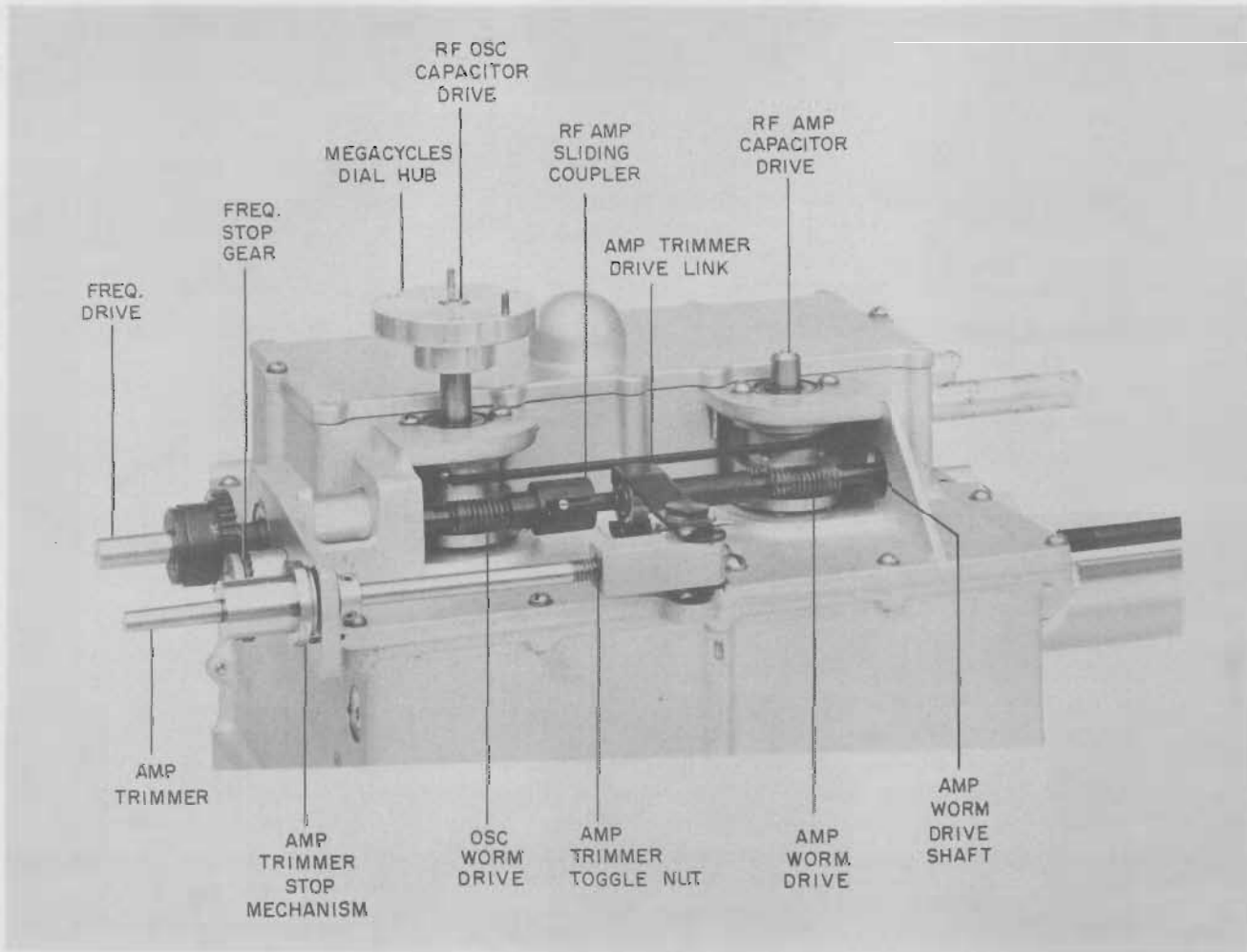

Fig. 6. R-F Tuner Drive Mechanism

608D 5/19/55 Serial 192 and above #608D0006

sleeve bearings and rubbing surfaces - including the small pulleys used in the attenuator drive system - are lubricated with a light synthetic oil such as Shell Tonna oil G. The bakelite RANGE SELECTOR drive shaft and the attenuator drive shaft - not shown in the illustration - require Lubriplate grease #2 where they enter the r-f generator housing. In all cases, avoid overlubrication.

Lubrication Chart
(See Figures 6 and 10)

Oscillator and amplifier worm gears	Mixture of 90% Lubriplate #2 and 10% Molycote
AMP, TRIMMER stop mechanism	Light machine oil, such as Shell Tonna oil G
AMP, TRIMMER toggle nut	Same as above
AMP, TRIMMER drive link	Same as above
Amp, worm drive shaft	Same as above
Amp, sliding coupler	Same as above
Attenuator pulleys	Same as above
Attenuator drive shaft front panel bearing	Same as above
Attenuator housing guide slot	Lubriplate #2

4-4 LOCALIZING TROUBLE

The first step in correcting any trouble which may occur in the signal generator is to isolate the section of the equipment that causes the trouble. The various circuits of the 608D Signal Generator occupy easily defined areas and offer very good circuit accessibility. The locations of the various sections are shown in Figures 12, 13, and 14. Figures 15 and 16 will also prove helpful in locating circuits within the r-f generator housing.

Trouble ordinarily occurs in only one section of an equipment at one time; therefore, it is usually necessary to correct only the one trouble. Isolation of a circuit failure is best accomplished by considering the basic sections shown in the block diagrams in Figures 3 and 4. Careful determination of the nature of a trouble symptom

usually leads to the section at fault. To aid in servicing, a trouble-shooting chart that indicates certain possible specific troubles and their symptoms and a signal tracing blank diagram are included. In addition, tube socket voltage and resistance diagrams and the schematic diagram for the complete equipment are included at the end of this section.

4-5 POWER SUPPLY TROUBLE SHOOTING AND ADJUSTMENT

Table 3 systematically locates troubles in the power supply section using a reliable 5,000 ohm/volt multimeter. The point at which a voltage and resistance is to be measured is listed in column 1. A correct voltage reading obtained from the second column indicates the particular circuit tested to be operating properly and may be passed by. An incorrect or unstable voltage indication should be corrected as instructed in the service note in the last column. All voltages are measured from chassis ground. When possible, use a variable line transformer to adjust the line voltage between 105 and 125 volts when measuring the power supply voltages. Marginal operation is quickly detected in this manner, as the regulated voltages should remain stable during such line voltage changes. Refer to Fig. 17a at rear of manual.

Table 3. Power Supply Trouble Shooting Chart

Measure Voltage At:	Normal Indication	Service Note
1. T1 (filament winding)	6.3 volts a-c rms	This voltage will read between 6.2 and 6.3 volts rms when the line voltage is 115 volts. A noticeably higher or lower voltage indicates that the line voltage is significantly more or less than 115 volts.
2. C45 (across terminals)	-165 volts d-c (regulated)	This is a stable regulated voltage accurately adjusted by R80. If this voltage is significantly high, low, or erratic, check voltage across V15 which should be a steady 150 volts. For excessively high output, check V14; for too low output,

608D 5/19/55 Serial 192 and above #608DD006

Table 3. Power Supply Trouble Shooting Chart (Contd.)

Measure Voltage At:	Normal Indication	Service Note
		<p>check V16A and the voltage applied to V16A (260 vdc). A weak selenium rectifier CR6 which supplies low voltage to the regulator will cause unstable operation of the regulator.</p>
<p>3. Resistor board (red leads)</p>	<p>+225 volts d-c (regulated)</p>	<p>This is a stable regulated voltage accurately adjusted by R71. If this voltage is significantly high, check V12; if too low, check V13 and the voltage applied to V13 (360 vdc). A weak selenium rectifier CR4 or CR5 which supplies low voltage to the regulator will cause unstable operation of the regulator.</p>
<p>4. T2 (Terminal 4)</p>	<p>7.6 volts as read on average responding meter calibrated in rms volts.</p>	<p>This is stable square wave voltage that must be measured by an average reading meter calibrated in rms volts and is accurately adjusted by R87. This voltage is applied only to the three r-f tubes within the r-f generator housing. If this voltage is significantly high (8 volts), one of the r-f tube filaments may be open or the heater supply multivibrator is far out of adjustment.</p>

608D 5/19/55 Serial 192 and above #608D006

4-6 SYSTEM ANALYSIS CHECK CHART

The schematic diagram at the end of the manual contains a series of test points which are listed below with measurement data taken at each test point. Measurements made at these points provide positive means of isolating a source of trouble to a small circuit area. When a circuit gives a faulty indication at a test point, the measurement may be analyzed to determine the type of failure, for example, insufficient gain through an amplifier normally indicates a weak tube. Distortion may indicate a gassy tube, shorted coupling capacitor, faulty resistor, etc. A faulty resistor is easily located by voltage and/or resistance measurements at the tube socket terminals and by comparing the readings with those given in the tube-socket voltage-resistance diagrams at the rear of the manual. A short circuited capacitor is usually located by measuring zero or low resistance across the capacitor with an ohmmeter. An open capacitor may be isolated by shunting the suspected component with a new one while noting instrument operation and by looking for an improvement in the usual signs of oscillation or instability. Listed with the check points are paragraph references for detailed information regarding a particular measurement. The indicated test point voltages are made to ground with a 20,000 ohm/volt multimeter. In some measurements a higher impedance meter or one having greater sensitivity is required and is so noted. In some measurements in the power supply it is more convenient to measure voltage from the -165-volt supply than from chassis ground and is so indicated. Begin measurements with signal generator set for 0 dbm output level and CW operation, then shift the controls as instructed in the chart. Follow steps in order given; some steps presume that previous measurements have given satisfactory indications. Set the front panel controls as shown below and proceed with the checks in the chart.

Power Switch	ON
MOD. SELECTOR	CW
FREQUENCY RANGE	D
FREQ.	100
MOD. LEVEL	minimum
AMP. TRIMMER	Set for maximum output.
OUTPUT LEVEL	Set for SET LEVEL reading on OUTPUT VOLTS meter.
ATTEN	0 dbm
XTAL CAL GAIN	maximum

Table 4. System Analysis Check Chart

Step & Test Point	608D Control Position	Normal Indication	Possible Cause of Abnormal Indication
1	Operate as described in Para. 4-6. Set MOD. SELECTOR to: CW, max. output CW, min. output PULSE operation	260 vdc, 1.4 vac 90 ma dc 95 ma dc 82 ma dc	Excessive ripple, C42. Low voltage, CR6 or excessive current drawn by following circuits.
2	Same as Step 1	-165 vdc, 5.5 milli-volts ac	See Table 3, Item 2.
3	Same as Step 1 Set for: CW, max. output 400\ MOD. output PULSE operation	+340 vdc, 2.7 vac 155 ma dc 175 ma dc 147 ma dc	Excessive ripple, C40. Low voltage, CR4, CR5 or excessive current drawn by following circuits.
4	Same as Step 1	+225 vdc 5.5 milli-volts ac	See Table 3, Item 3.
5	Any position	7.6 volts ac, square wave	See Table 3, Item 4.
6	Set for CW at low freq. end of: "A" band "B" band "C" band "D" band "E" band	103 vdc 89 vdc 87 vdc 82 vdc 80 vdc	When out of oscillation a voltage of approximately 87 is read on all bands. Check oscillator tube and associated component.

608D 5/19/55 Serial 192 and above #608D0006

Table 4. System Analysis Check Chart (Contd.)

Step & Test Point	608D Control Position	Normal Indication	Possible Cause of Abnormal Indication
7.	Set for CW operation	+110 vdc	High voltage indicates a weak V7 or open plate circuit.
8	Set for CW operation. Set OUTPUT LEVEL to: minimum SET LEVEL maximum	Measure voltage across R82 0 vdc +1.4 vdc (approx.) +7.0 vdc	With output level set to max. and RANGE selector set between ranges, the d-c voltage should not exceed -4.5 volts to ground.
9	Set for CW operation. Set OUTPUT LEVEL to: minimum SET LEVEL maximum	+31 vdc +6 vdc (approx.) -7 vdc, -26 vdc when disconnected from r-f generator	With modulator disconnected from filter FL6, inadequate voltage range indicates poor V5 or control circuit measured in Step 11.
10	Set for 400 ω Modulation at 10 mc and 100 mc 10% mod. 30% mod. 50% mod. 80% mod.	AC Volts <u>10 mc</u> <u>100 mc</u> .48 .3 1.3 .75 2.2 1.2 3.7 1.8	Insufficient signal indicates low amplification farther back in the modulator, see Steps 14, 15, and 16.
11	Set for CW operation. Set OUTPUT LEVEL to: minimum SET LEVEL maximum	Use electronic voltmeter +23 vdc - 2 vdc -30 vdc	Rough, insufficient, or excessive voltage check R34, R37, R39, and R40.

608D 5/19/55 Serial 192 and above #608D006

Table 4. System Analysis Check Chart (Contd.)

Step & Test Point	608D Control Position	Normal Indication	Possible Cause of Abnormal Indication
12	Turn off for this measurement.	53 ohms	25 ohms indicates shorted C37, infinite indicates open R58.
13	Set for 400 and 1000 \wedge internal modulation operation	2 vac rms +6.4 vdc	Adjust R7 to obtain correct voltage, if necessary, change I1.
14	Set for 400 \wedge modulation at 10 mc 10% 30% 50% 80%	Use electronic voltmeter .017 vac .048 vac .083 vac .141 vac	Approximate voltages required for modulation of the r-f output signal.
15	Set for 400 \wedge modulation at 10 mc 10% 30% 50% 80%	Use electronic voltmeter .068 vac .195 vac .32 vac .56 vac	Low output indicates weak V1. Gain should be approximately equal for these signal levels.
16	Set for 400 \wedge modulation at 10 mc 10% 30% 50% 80%	.58 vac 1.66 vac 2.8 vac 4.8 vac	Low output indicates weak V3. Gain should be approximately equal for these signal levels.
17	Set for 400 \wedge modulation at 10 mc 10% 30% 50% 80%	.014 vac .044 vac .174 vac 1.2 vac	Low output indicates weak CR2 and would be accompanied by low indication on the r-f OUTPUT VOLTS meter. See Paragraph 4-14.

608D 5/19/55 Serial 192 and above #608D006

Table 4. System Analysis Check Chart (Contd.)

Step & Test Point	608D Control Position	Normal Indication	Possible Cause of Abnormal Indication
18	Set for CW operation. Set OUTPUT VOLTS meter to read: .1 volt half scale SET LEVEL full scale	.05 vdc .16 vdc .23 vdc .32 vdc	These voltages vary depending upon the forward resistance of CR2 and CR3.
19	Set for 400 μ modulation at 10 mc 10% 30% 50% 80%	.39 vac 1.0 vac 1.55 vac 2.50 vac	Low voltage indicates weak V18 or V19.
20	Set for CW operation at any check point	4 vdc	If voltage is below 1 volt and beat-frequency signals are not obtainable, check CR1 and V9. See Paragraph 4-15.
21	Set for CW operation at any check point	43 vac with J3 connected to 600 ohm load	Low output indicates weak V10 or V11.

608D 5/19/55 Serial 192 and above #608D006

4-7 REPLACEMENT OF ELECTRON TUBES

When replacing tubes in the Model 608D, it is recommended that a check be made on the operation of the instrument before and after each new tube trial; and if no improvement is noticed, the original tube should be returned to the socket. Figure 7 locates all electron tubes in the equipment. Table 5 lists the tubes of the signal generator with a suggested check and paragraph reference if adjustments are necessary.

Table 5. Adjustments and Checks
Required After Tube Replacement

Tube Position	Check or Paragraph Reference
V1	Check operation with modulation.
V2	Check operation with internal modulation.
V3	Check operation with internal modulation.
V4	Check operation with internal modulation.
V5	Check range of output level control (should obtain 0 to full-scale deflection on OUTPUT VOLTS meter).
V6	See paragraph 4-8.
V7	Check maximum power for CW operation (should obtain full-scale deflection on OUTPUT VOLTS meter).
V8	See paragraph 4-9.
V9	See paragraph 4-10.
V10	Check loudness of calibrator signal.
V11	Check loudness of calibrator signal.
V12	See paragraph 4-11.
V13	See paragraph 4-11.
V14	See paragraph 4-11.

608D 5/19/55 Serial 192 and above #608D006

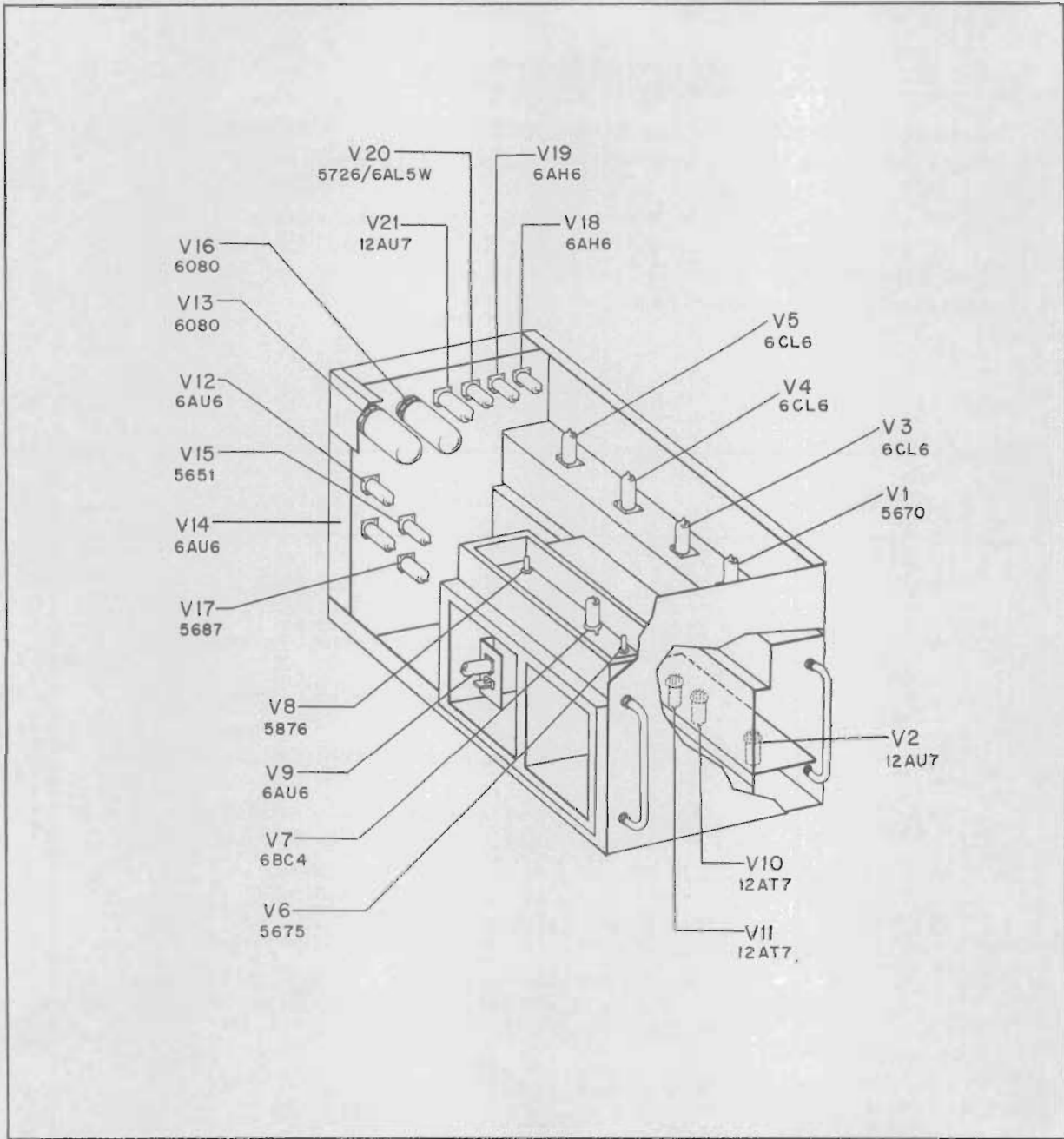

Fig. 7. Tube Location Diagram

608D 5/19/55 Serial 192 and above #608D006

Table 5. Adjustments and Checks Required After Tube Replacement (Contd.)

Tube Position	Check or Paragraph Reference
V15	See paragraph 4-11.
V16	See paragraph 4-11.
V17	See paragraph 4-11.
V18	Check for indication of modulation percentage.
V19	Check for indication of modulation percentage.
V20	Check for indication of modulation percentage.
V21	Check zero set of PERCENT MODULATION meter.

4-8 RADIO FREQUENCY OSCILLATOR TUBE REPLACEMENT
(Figs. 8, 16)

Replacement of the radio frequency oscillator tube V6 may affect the calibration of the frequency dial and may change the heater supply voltage for the oscillator, buffer, and power amplifier tubes. In addition, the plate current of new type 5675 pencil triode tubes may differ widely in a given application. For this reason, the heater voltage must be checked and, if necessary, reset to proper value; plate current must be held to between 18 and 27 milliamperes by tube selection. To replace oscillator tube V6, refer to Figure 8 and proceed as follows:

- a. Remove frequency dial and top plate from r-f generator housing to gain access to tube compartment. The frequency dial is accurately indexed on its hub by two pins which assure exact positioning upon replacement of dial on hub.
- b. Remove socket from base of V6 by straight pull.
- c. Remove cathode clip from tube.

608D 5/19/55 Serial 192 and above #608D0006

RF POWER AMPLIFIER

RF OSCILLATOR

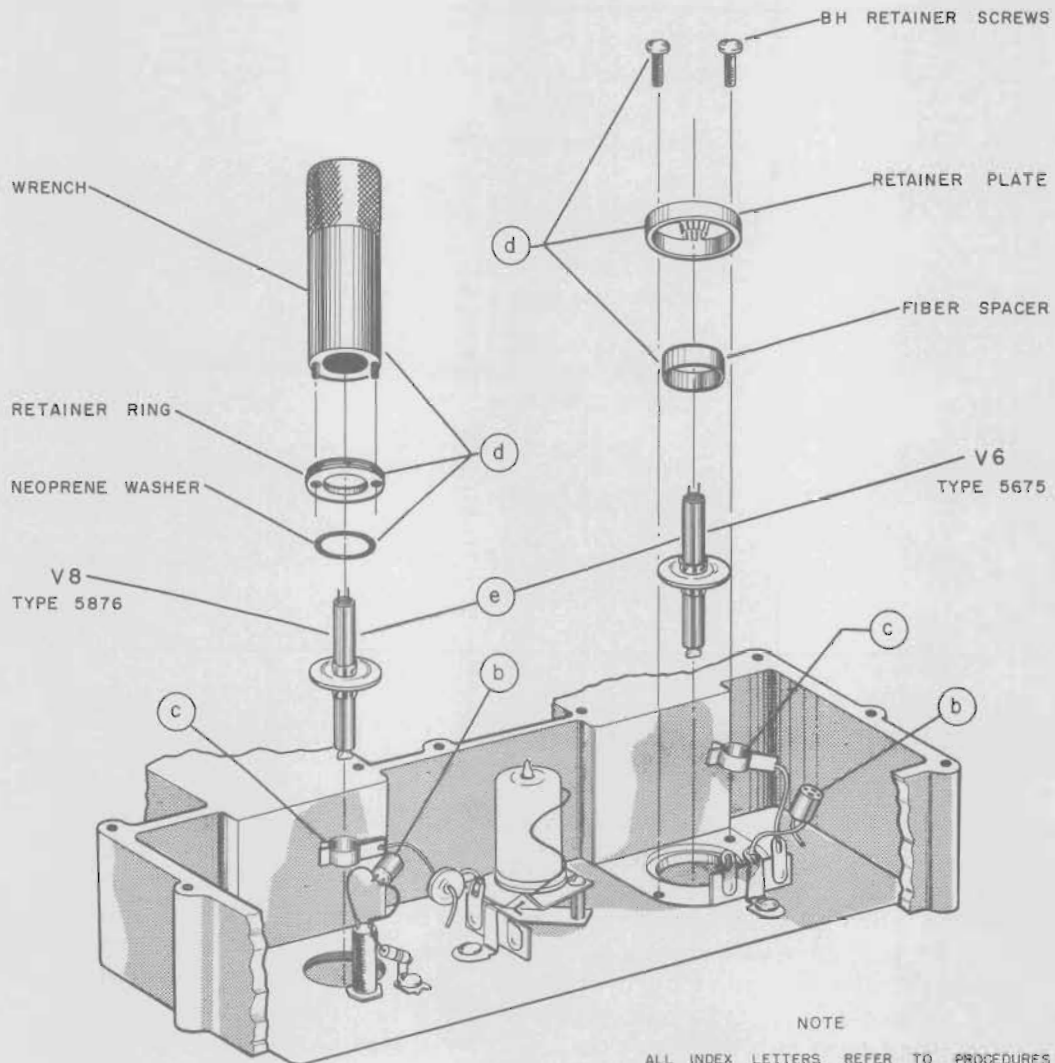

Fig. 8. R-F Oscillator and Amplifier Tube Replacement Diagram

608D 5/19/55 Serial 192 and above #608D006

- d. Remove the two 6-32 screws holding retainer plate; then remove plate and fiber spacer.
- e. Lift tube gently from hole by straight pull.
- f. Replace tube in reverse order of above steps.
- g. Using an average-reading, a-c electronic voltmeter calibrated in rms volts, such as the -hp- Model 400A, C or D, measure the voltage on the inside terminal of FL1. If necessary, adjust R87 to obtain a reading of 7.1 volts between the inside terminal of FL1 and ground.
- h. With equipment turned off, break green lead to C15, a feed-thru type capacitor in the r-f generator tube compartment, and insert a 0-50 ma millimeter.
- i. Set the frequency range switch to the E band and turn equipment on. Millimeter should read between 18 and 27 ma. If it does not, try another replacement tube.
- j. Using the internal beat-frequency calibrator, check the frequency calibration throughout the range of the signal generator, noting points that are significantly off frequency.
- k. To correct the frequency calibration at the high frequency end of all bands simultaneously, adjust trimmer capacitor C18, which is accessible in the tube compartment in r-f generator housing. This adjustment has only minor effect at the low frequency ends of the ranges.

4-9 RADIO FREQUENCY AMPLIFIER AND BUFFER TUBE REPLACEMENT (Figs. 8 and 16)

Replacement of the r-f amplifier and buffer tubes can affect the heater voltage applied to r-f tubes in the generator housing and may also limit the maximum power output available from the signal generator. Both of these possibilities should be checked as described below. To remove r-f amplifier tube V8 and buffer V7, refer to Figure 8 and proceed as follows:

- a. Remove frequency dial and top plate from r-f generator housing to gain access to tube compartment.
- b. For buffer V7 replace tube and proceed with step h.
- c. For amplifier V8 remove socket from base of V8 by straight pull.

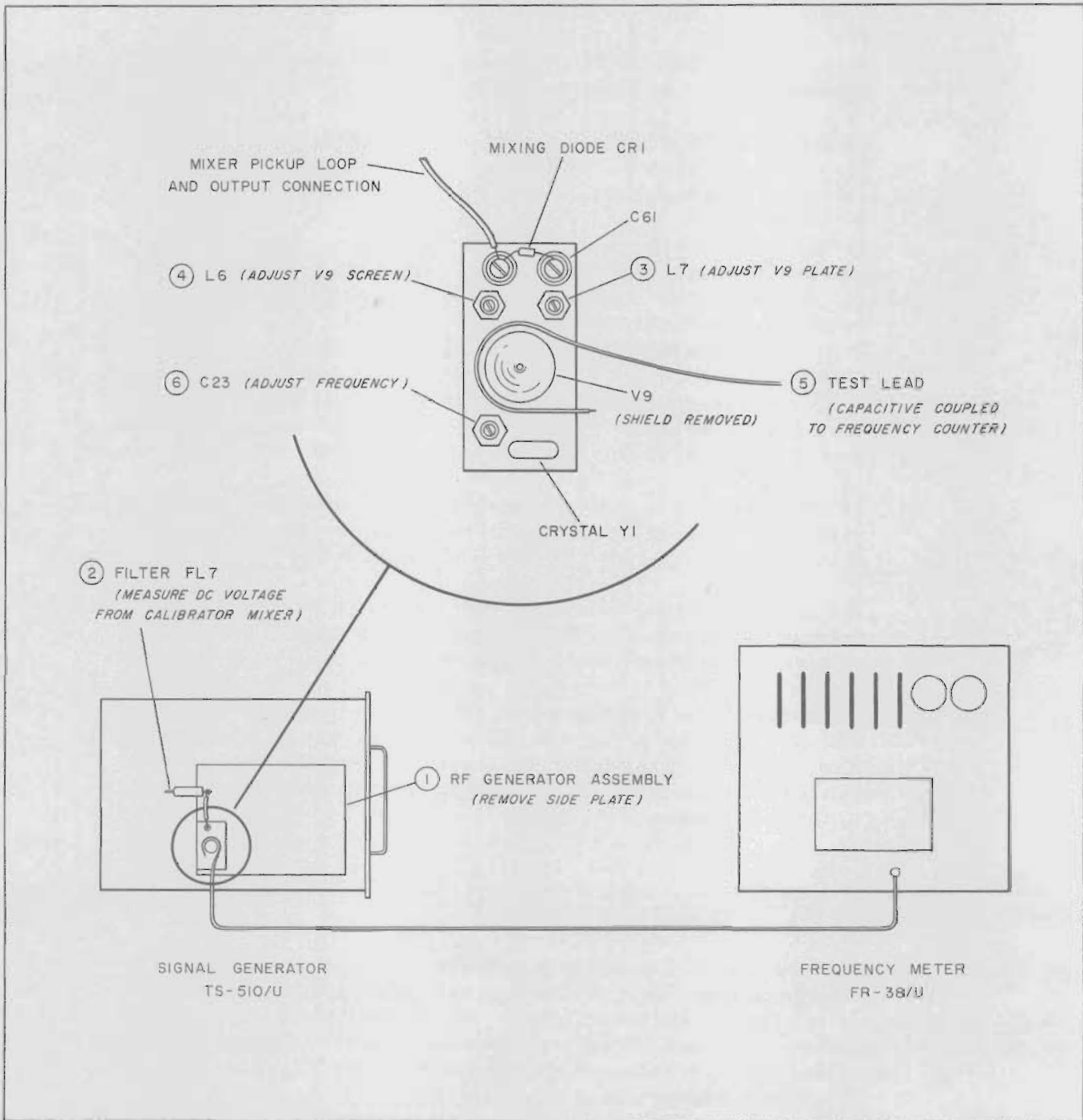

Fig. 9. Diagram Showing Adjustment for Internal Freq. Calibrator

- d. Remove cathode clip from tube.
- e. Using the special wrench located on instrument chassis convenient to generator housing, loosen threaded retainer ring which holds V8 in housing. Remove retainer ring and neoprene washer.
- f. Withdraw old tube and replace with new type 5876 tube.
- g. Following replacement of V8, check and, if necessary, adjust the heater voltage as instructed in paragraph 4-8g for the r-f oscillator tube.
- h. Check the power output throughout the full frequency range of the signal generator reading the self-contained power level meter with the AMP. TRIMMER control set for maximum output. A full-scale reading should be obtainable over the entire frequency range.

4-10 XTAL FREQUENCY OSCILLATOR TUBE OR CRYSTAL REPLACEMENT (Fig. 9)

To gain access to the beat frequency oscillator, remove the side cover to the r-f generator housing. The entire crystal oscillator is constructed on a bracket mounted on the rear wall of the r-f amplifier compartment. Mounted on the bracket are three adjustments, L6, L7, and C23. L6 and L7 are adjusted for peak output at the factory, and it is not expected that further adjustment will be necessary. However, if the frequency of the oscillator is found to be off by greater than 500 cycles (0.01%), C23 may be adjusted to bring the frequency of the oscillator to 5 megacycles. To check the frequency of the crystal calibrator and to make the adjustments described above, refer to Figure 9 and proceed as follows:

- a. Remove signal generator from its cabinet, connect to power source and allow to warm up for 15 minutes.
- b. Remove side plate from the r-f generator housing to gain access to the calibrator oscillator.
- c. Connect a d-c voltmeter to the outside terminal of filter FL7.
- d. Adjust L7 to peak the d-c voltmeter indication. This voltage should be between 1-1/2 and 4 volts.
- e. Adjust L6 (screen adjustment) to dip the d-c voltmeter indication. More than one dip is sometimes obtained, any one of which may be used.

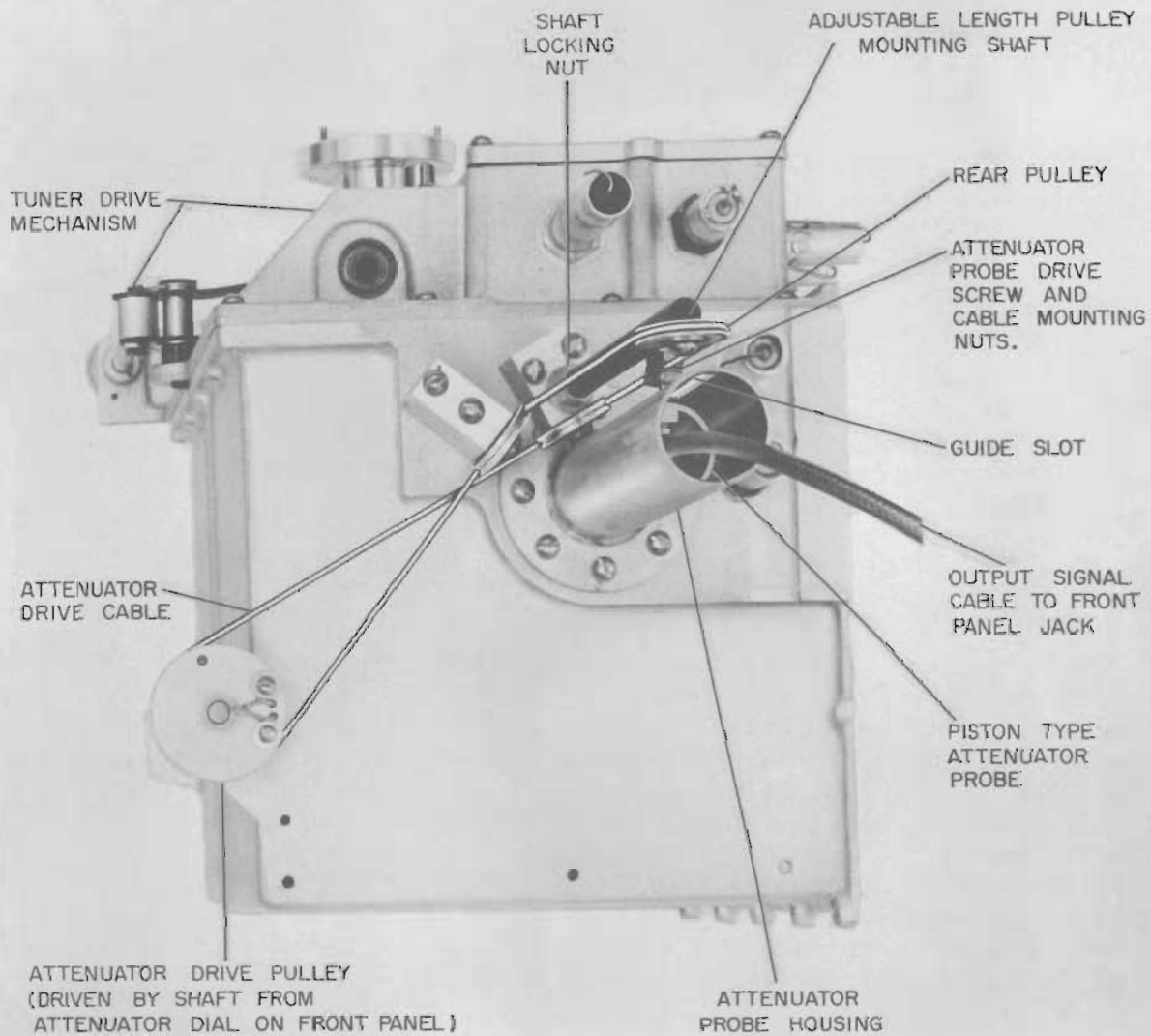

Fig. 10. R-F Generator Assembly Rear View,
Showing Output Attenuator Drive System.

608D 5/19/55 Serial 192 and above #608D006

- f. Recheck setting of L7. Capacitively couple a lead from V9 to any suitable frequency measuring instrument.
- g. Adjust C23 to obtain exact 5 mc signal as read on the frequency meter. No further adjustment is necessary if the required frequency and output level are obtained.

4-11 REPLACEMENT OF ELECTRON TUBES WITHIN THE REGULATED POWER SUPPLIES

The output voltage from either or both of the regulated power supplies may be affected slightly by a change in any one of the tubes within the supplies. The two power supplies are interdependent in that the setting of the +225-volt supply depends upon a reference point established by the -165-volt supply; therefore, a tube change in the -165-volt supply should be followed by a check of the +225-volt supply. All tubes and components in the power supplies are located on the chassis to the rear of the signal generator.

To check the output voltage from the power supplies following service or tube replacement, refer to Figure 13 and proceed as follows:

- a. With the MOD. SELECTOR switch set to the 1000 position and the other controls in any position, turn equipment on.
- b. Connect the positive lead of a voltmeter having a sensitivity of 5000 ohms per volt or better to ground.
- c. Connect the negative lead to the lead connecting both ends of metallic rectifier CR6 on the rear chassis.
- d. Voltage should now read -165 volts. If necessary, adjust R80 to obtain 165 volts. This voltage should then remain stable with line voltage changes between 103.5 and 126.5 volts.
- e. Reconnect voltmeter with the negative lead to ground and the positive lead to pin 6 of V13.
- f. Voltage reading should be +225 volts. If necessary, adjust R71 to obtain +225 volts. This voltage must remain substantially constant with line voltage changes between 103.5 and 126.5 volts.
- g. Connect an average-reading a-c vacuum tube voltmeter between filter FL1 (red identification band) and ground. The voltage at this point is the filament voltage for the r-f oscillator and r-f power amplifier and is furnished by V17, a square-wave multivibrator.

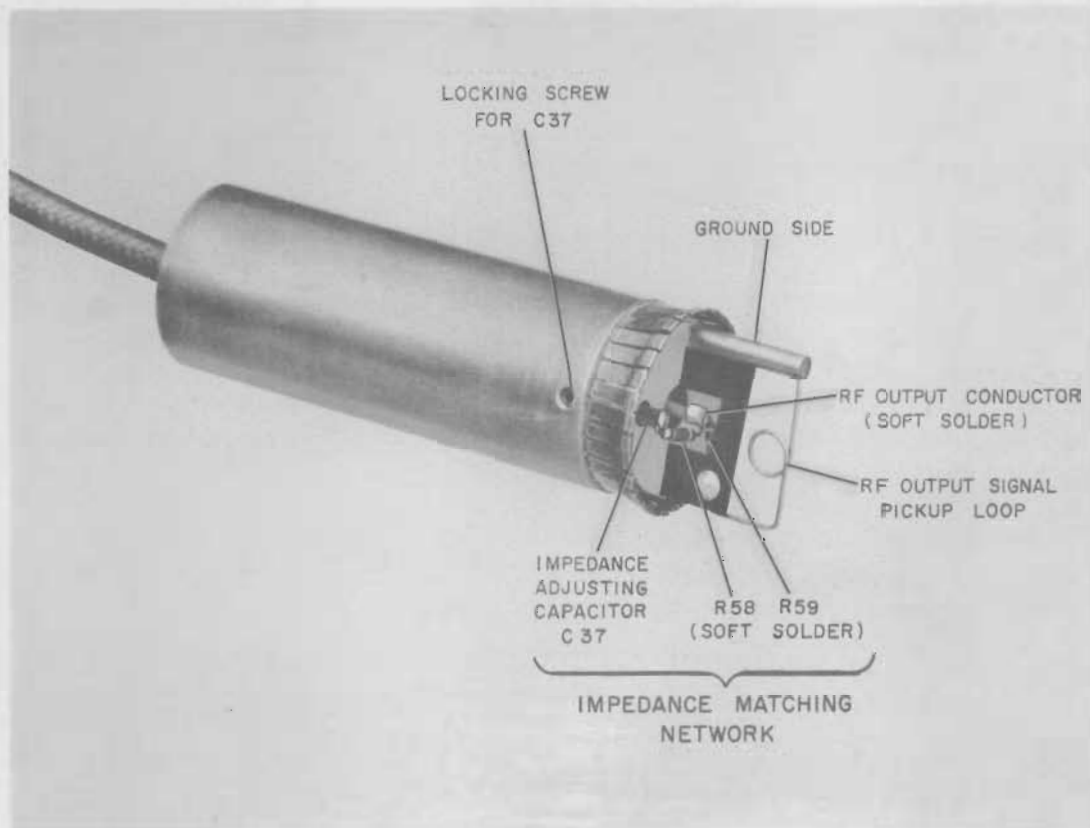

Fig. 11. R-F Output Attenuator Probe, Showing Pickup Loop and Impedance Matching Network

608D 5/19/55 Serial 192 and above #608D006

h. Adjust R87 for 7.6 volts rms.

4-12 ATTENUATOR PROBE REPLACEMENT (Figs. 10, 11)

If the electrical components of the output attenuator are damaged, such as described in the "CAUTION" on page 11, repair or replacement is necessary. This condition may be confirmed by measuring either the d-c resistance or the VSWR of the attenuator at the RF OUTPUT jack. The d-c resistance should be 53 ohms and the VSWR not greater than 1.2. If investigation shows an attenuator to be defective, proceed as follows:

CAUTION

During removal and replacement of the probe, extreme care must be exercised. The probe consists of a cylindrical metal tube with a series of spring contact fingers around its periphery at one end, which can be accidentally bent or twisted. Also, it will be noted that one of the fingers is bent toward the center of the probe slightly. Do not attempt to straighten it since it has been made this way to assure clearance between the probe and the end of the guide slot in the attenuator housing. It is of greatest importance to make certain that the probe is not subjected to shock. If the probe is subjected to shock, the electrical components attached to the end of the probe can be broken or their position altered with a consequent change in the electrical characteristics of the probe.

- a. Turn the attenuator control on the front panel until the probe reaches the end of its travel to the rear of the attenuator housing.
- b. Refer to Figure 11b. Remove the nut and washer that hold the drive cable in the probe drive screw in the top of the attenuator probe. Lift the cable out of the screw slot.
- c. Remove probe drive screw from probe body by removing inner nut and unscrewing.

Serial 192 and above #608D006
608D 5/19/53

- d. Carefully remove the probe by sliding it out of the attenuator housing.
- e. If the damage to the attenuator probe is limited to a burned out resistor and if a replacement resistor is available, the attenuator may be repaired by carefully unsoldering the old resistor, using a low temperature soldering iron, and replacing the resistor. Soldering must be done quickly and neatly with low temperature solder. Care must be taken to duplicate the original workmanship as closely as possible by positioning the new part exactly as the old one was and by applying as little heat in the soldering process as is possible. Capacitor C37 need not be adjusted unless it too has been damaged. This capacitor consists of a metal pin with a thin plastic coating within a sleeve. The sleeve is retained by a #4 Allen screw in the side of the probe body. If the coating on the pin is pierced, the pin must be replaced. Again it is important to retain the original positioning. Loosening the set screw shown in Figure 11 allows for adjustment or replacement of the pin and sleeve.
- f. If repair is not possible, the probe and cable must be replaced. It will then be necessary to remove the RF OUTPUT jack from the front panel and release the cable from the clamp holding the cable to the top of the side gusset. The entire probe assembly may then be removed from the instrument. Replacement probes are complete with cable and panel jack and require no adjustment of the impedance-matching network upon installation.
- g. Insert the new or repaired probe in the attenuator housing. Care must be taken in starting the probe into the housing since the diameter at the probe contact fingers is slightly greater than the inner diameter of the housing. The contact fingers should be depressed slightly while starting the probe into its housing. UNDER NO CIRCUMSTANCES SHOULD THE PROBE BE FORCED.
- h. Replace the split drive screw in the probe, making certain that the screw slot is parallel to the axis of the housing.
- i. Set the attenuator drive cable in the screw slot and replace both washers and nut. Do not tighten the nut. The cable must move freely through the slot until the probe penetration has been set.
- j. Secure the r-f cable to the clamp on the side gusset. (Cable routing is shown in Figures 13 and 14.)

- k. Connect the instrument to a source of 115-volt a-c power. Turn on the power switch.
- l. Unless otherwise specified, the operating controls should be set as follows:

MOD. SELECTOR	CW
FREQUENCY CONTROL	20 megacycles
FREQUENCY RANGE	A band
AMP. TRIMMER	Adjust for max. output
OUTPUT LEVEL	Adjust for SET LEVEL
MOD. LEVEL	Counterclockwise
Attenuator	0 dbm

- m. Connect a power meter, such as the -hp- Model 430B, through a bolometer mount (-hp- Model 476A or equivalent) to the RF OUTPUT jack.
- n. Remove r-f generator side plate so that clearance between the attenuator probe and r-f amplifier tank may be observed.

CAUTION

The following step must be executed as carefully as possible to insure that the pick-up loop does not make contact with any one of the amplifier coils. These coils are the power amplifier tuning coils and are at B+ potential. Contact with the attenuator pick-up loop would be destructive to the attenuator components.

- o. With the attenuator dial set exactly on 0 dbm and the OUTPUT VOLTS meter set to SET LEVEL, manually advance the attenuator probe into the housing until the r-f output signal is exactly 1 milliwatt (0 dbm) as read on the external power meter.
- p. Tighten down the nut on the split screw so that the probe may be actuated by its drive system. Carefully check to see that there is clearance between the various turret coils and the pick-up loop when the attenuator dial is set to +4 db.
- q. Replace r-f generator side plate. Using the power meter, check the output at 0 db (1.0 milliwatt) at the higher frequencies on the B, C, D, and E bands. If necessary, the

self-contained output meter calibration can be adjusted by means of R62 (see Figure 14). See paragraph 4-15 for complete OUTPUT VOLTS meter recalibration instructions.

4-13 REPLACEMENT OF LAMP I1

Lamp I1 acts as a thermal resistance having a high positive temperature coefficient and is used to maintain constant output voltage from the 400- and 1000-cycle oscillator. The S6 type lamps used for this purpose ordinarily vary widely from one lamp to another and produce widely varying output voltage from this oscillator. Potentiometer R7 is provided for adjustment of the oscillator output voltage for various S6 lamps,

After the lamp I1 has been replaced, the oscillator voltage, as measured at pin 3 of V2, should be adjusted to 2 volts rms; if it cannot be adjusted to this value, another lamp must be tried.

4-14 CALIBRATION OF THE PERCENT MODULATION METER

Recalibration of the PERCENT MODULATION meter may be necessary following a repair of the modulation measuring circuits or after replacement of the meter itself. The method of calibration outlined below requires the use of a peak-reading electronic voltmeter capable of measuring a-c voltages to 500 megacycles, such as the -hp- Model 410B, and requires a tuned step-up transformer to obtain adequate output voltage from the generator for measurement. Basically, this method of modulation measurement consists of measuring the peak value of the r-f output signal with and without modulation. A doubling of the peak output voltage indicated on the multimeter represents 100% modulation of the output signal, while lesser percentages of modulation are indicated by proportionally smaller voltage increments.

To measure modulation by the voltmeter method, it will be necessary to fabricate a tuned circuit similar to that shown below. Materials at hand may be used as substitutes for those listed.

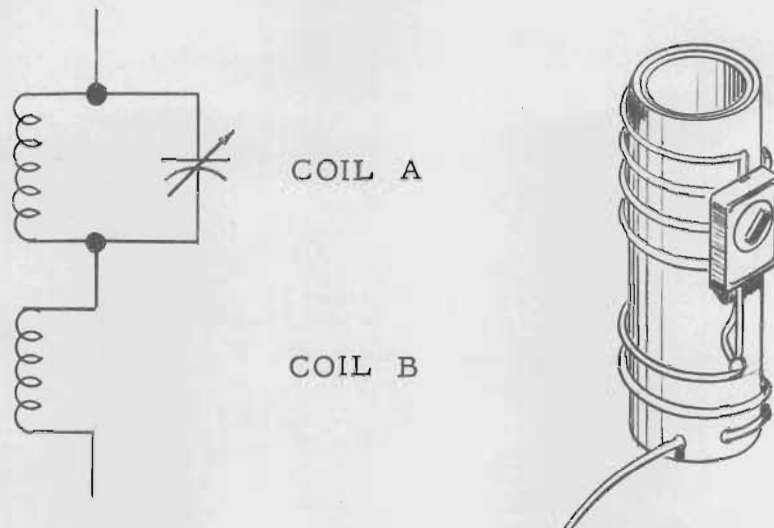

Coil form - 3/4 in. dia by approx. 2 in. long.
Ceramic, polystyrene or similar material.

Coil A - 5 turns of solid #22 wire spaced 1/8 in. between turns.

Coil B - 2 turns of solid #22 wire spaced 1/8 in. between turns. (Approx. 1/4 in. spacing between coils A and B.)

Tuning capacitor - 7 to 45 μ f.

The following procedure for calibrating the PERCENT MODULATION meter may be used with either internal or external modulation.

- a. With the controls set as below, turn the power switch on and allow the instrument to warm up,

FREQUENCY RANGE	C band
MEGACYCLES dial	75 to 85 mc
MOD. SELECTOR	1000
AMP. TRIMMER	Adjust for max. output
OUTPUT VOLTS meter	Adjust to SET LEVEL
PERCENT MODULATION	Adjust for 0%
Attenuator	0 dbm

- b. Connect the signal generator to the test apparatus as shown in the diagram below.

-hp- Model 608C
VHF Signal Generator

-hp- Model 410B
VHF Vacuum Tube
Voltmeter

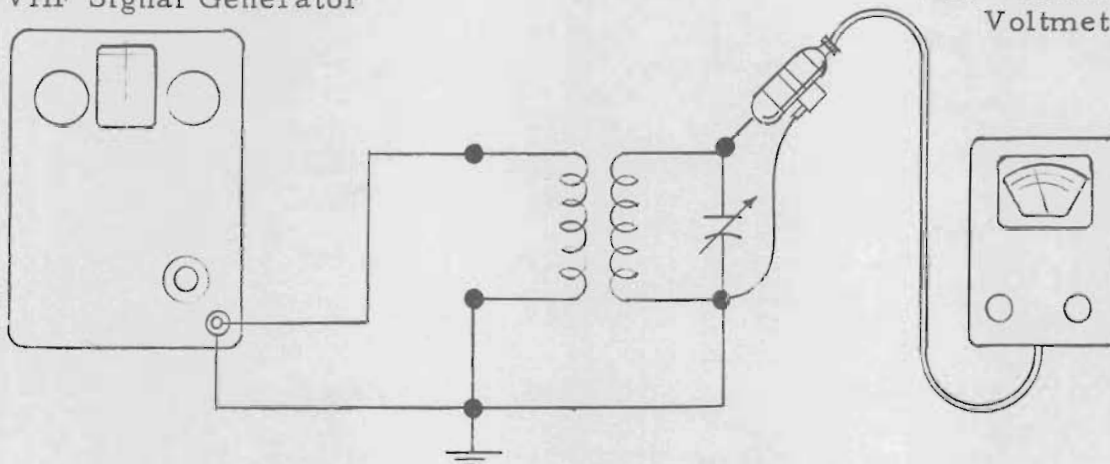

- c. Set the 410B voltage range switch to the 10-volt a-c range.
- d. Adjust the capacitor on the r-f transformer to obtain greatest output as read on the vacuum tube voltmeter.
- e. Reading from the 0 to 3 volt scale on the multimeter, adjust the output attenuator on the 608D for a reading of 1 volt on the multimeter.

NOTE

The actual voltage from the tuned circuit will be within the 10-volt range; however, the linear portion of the 3-volt scale can be used as a modulation indicator since the 1-volt calibration mark now represents 0% modulation and the 2-volt calibration will represent 100% modulation, with the intermediate calibrations corresponding to the calibrations on the PERCENT MODULATION meter in the signal generator. Accuracy of modulation indication as read from the 410B Voltmeter will be within $\pm 5\%$.

- f. Adjust the MOD. LEVEL control for a reading corresponding to 1.8 on the 410B Voltmeter.

- g. Application of high percentages of modulation may result in a slight rise (1/2 db) in the OUTPUT VOLTS meter indication. If necessary, readjust the OUTPUT LEVEL control to obtain a reading at SET LEVEL on the OUTPUT VOLTS meter.
- h. Adjust R104 (see Figure 13) to provide a reading of 80% on the PERCENT MODULATION meter.
- i. Check the meter calibration for other modulation percentages, e.g., 1.1 on the voltmeter corresponds to 10% modulation, 1.2 to 20%, etc. The setting of R104 may be refined to obtain best overall calibration accuracy of the PERCENT MODULATION meter.

NOTE

For this procedure the OUTPUT LEVEL control must be set at all times to provide a reading at SET LEVEL on the OUTPUT VOLTS meter.

4-15 OUTPUT VOLTS METER CALIBRATION AND R-F POWER MONITOR SERVICE

Recalibration of the OUTPUT VOLTS meter may be necessary following replacement of the attenuator probe, components in the power monitoring circuits, or replacement of the meter itself. If it becomes necessary to replace CR2 or R60 in the power monitor assembly, the frequency response of the meter circuit will also be affected and must be readjusted.

— CAUTION —

Do not disturb the positioning of the components in the r-f power monitor assembly (see Figure 15) until instructed to do so in procedure. The position and lead lengths of resistor R60 and L17 and the characteristics of crystal CR2 all affect the frequency response of the meter circuit, mostly on the E band and to a lesser degree on the D band. To restore "flat" frequency response requires care and skill in repositioning.

The method of calibration outlined below requires the use of a 50-ohm bolometer mount and power meter, such as the Hewlett-Packard Model 476A Universal Bolometer Mount and Model 430B Power Meter, to measure the r-f signal power from the generator. To reset the frequency response of the higher bands, such as following replacement of CR2 or R60, the OUTPUT VOLTS meter must first be checked for accuracy as described in steps "a" through "i" below, then adjusted as described in step "j". Proceed as follows:

- a. Connect the 608D to a source of 115-volt a-c power. Turn on the power switch and allow to warm up with the operating controls in the following positions:

MOD. SELECTOR	CW
FREQUENCY CONTROL	75 to 80 megacycles
FREQUENCY RANGE	C band
AMP. TRIMMER	Adjust for max. output
OUTPUT LEVEL	Adjust for SET LEVEL
MOD. LEVEL	Extreme counterclockwise
Attenuator	0 dbm

- b. Connect the power meter and bolometer mount to the RF OUTPUT jack on the signal generator.
- c. With the attenuator set for exactly 0 dbm, adjust the OUTPUT LEVEL control to obtain exactly 0 dbm on the external power meter.
- d. If necessary, adjust R62 to obtain an exact reading at SET LEVEL on the self-contained OUTPUT VOLTS meter.
- e. Using the external power meter, check the 0 and +7 db calibration points of the OUTPUT VOLTS meter (points -4 and +3 decibels from the 0 dbm level).
- f. Adjust the OUTPUT LEVEL control to obtain -4 dbm as read on the external power meter. If necessary, adjust R62 to obtain a reading of 0 db on the self-contained OUTPUT VOLTS meter.
- g. Set OUTPUT LEVEL control for +3 dbm as read on the external power meter. If necessary, adjust R61 to obtain a reading of +7 db on the self-contained OUTPUT VOLTS meter.
- h. Because the two adjustments R61 and R62 are interactive, steps "f" and "g" must be repeated to obtain best overall accuracy of calibration.

- i. Recheck accuracy of calibration at SET LEVEL (+4 dbm) and, if necessary, adjust R62 to obtain an exact reading at this point.
- j. Recheck calibration at SET LEVEL at frequencies of 100, 250, and 400 megacycles. If the calibration is high or low at the higher frequencies, the OUTPUT VOLTS meter reading may be corrected by adjusting the inductance of L17. Shortening the coil (increasing the inductance) will decrease the meter reading as shown in the diagram below. Lengthening the coil (decreasing the inductance) will increase the meter reading.

CAUTION

Great care should be taken to change only the length of the coil and not to shift the positions of any other components in the power monitor assembly.

If the frequency response is satisfactory at all frequencies up to approximately 300 mc but tends to rise or fall at the higher frequencies, the pigtail connection of resistor R60 which connects to coil L17 may be adjusted very slightly to raise or lower the meter reading at the higher frequencies only. Again, great care must be used to adjust the positioning of only one component at a time and to follow each adjustment with a power measurement to see the exact effect of the adjustment. In general, increasing the capacity between this pigtail and ground may be expected to decrease the meter reading at only the higher frequencies.

The graph on the next page shows the increase or decrease in the reading of the OUTPUT VOLTS meter that is obtained at different frequencies when making each one of the three possible adjustments. Only minor adjustments should be made (very small change in physical position), using the graph for a guide as to the approximate results that may be expected.

608D 5/19/55 Serial 192 and above #608D0006

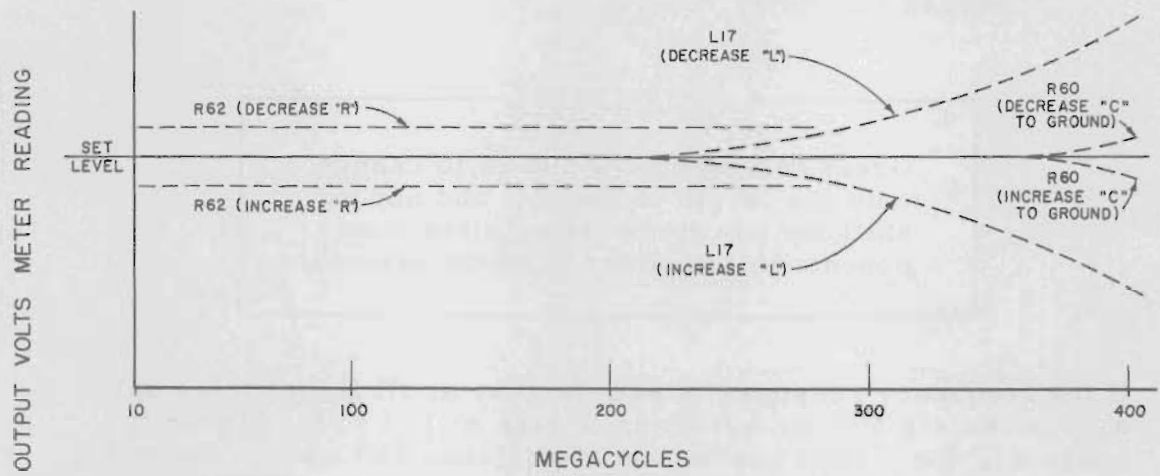

608D 5/19/55 Serial 192 and above #608D006

4-16 REPAIRING THE CALIBRATOR OSCILLATOR

To replace any of the components in the frequency calibrator oscillator circuit, other than the tube and crystals, the oscillator chassis must be removed from the r-f generator assembly as follows:

- a. With signal generator out of its cabinet, remove the side plate from the r-f generator housing.
- b. Unsolder the shielded heater power (black) lead from the feed-thru capacitor in the top of the compartment.
- c. Unsolder the shielded plate (white) lead from the tie point in the top of the compartment.
- d. Unsolder the output lead from filter FL7.
- e. Remove the two 6-32 machine screws attaching the oscillator chassis to the generator housing. The oscillator chassis is now free to be removed.

608D 5/19/55 Serial 192 and above #608D006

4-17. TROUBLE SHOOTING CHART

SYMPTOM	POSSIBLE TROUBLE	CHECK AND PARAGRAPH REFERENCE
<p>1. A. Low CW RF output (cannot obtain full-scale reading on output level meter).</p> <p>B. Low CW RF output (output level meter indicates normal output).</p> <p>C. Low CW output at low frequency end of the E band.</p> <p>D. Intermittent operation on any one band.</p>	<p>Low heater voltage from V17. Weak oscillator V6. " buffer V7. " amplifier V8.</p> <p>Low power supply voltage.</p> <p>Open attenuator impedance-matching network.</p> <p>Weak V6. Weak V8.</p> <p>Poor connections at contacts on oscillator or amplifier coil turrets.</p>	<p>Check heater voltage. If necessary, set as described in paragraph 4-11. Check V6 and V7 by measuring r-f signal at cathode of V8 in tube compartment. Should be 4 to 11 volts. Replace tubes to improve.</p> <p>Check the +225-volt and the -165-volt supplies.</p> <p>Check resistance of attenuator at output jack. Should be 53 ohms.</p> <p>Check by replacing V6.</p> <p>Check by replacing V8.</p> <p>Clean contacts. If necessary, bend turret contact for greater pressure.</p>
<p>2. Output signal cannot be reduced by OUTPUT LEVEL control (output meter remains upscale).</p>	<p>Weak V5.</p>	<p>Check by replacing V5.</p>
<p>3. A. Output level drifts.</p> <p>B. Output level drifts (with changes in line voltage).</p> <p>C. High residual hum on output signal may be read on PERCENT MODULATION meter when no modulation is applied.</p>	<p>Weak V6.</p> <p>Power supply does not regulate properly.</p> <p>Same as above.</p>	<p>Check V6 by replacing.</p> <p>Check stability of regulated +225- and -165-volt supplies. See paragraph 4-5.</p>

SYMPTOM	POSSIBLE TROUBLE	CHECK AND PARAGRAPH REFERENCE
4. Frequency calibration inaccurate at high frequency ends of all bands.	Tube characteristic differences following replacement of V6.	Adjust C18 for correct calibration at top of all bands. See paragraph 4-8.
5. Little or no indication from output meter.	Crystal diode CR2, CR3 for short. No r-f output.	See paragraph 4-15.
6. Change in mod. percent causes change in output level meter. (About 10% is normal.)	Overmodulation can be due to actual r-f signal being less than indicated or due to modulation being greater than the indicated amount.	Check amplitude of r-f output signal with external power meter. Check gain of modulation indicator amplifier. Check modulation of r-f carrier by viewing on oscilloscope.
7. Distortion of the modulation envelope, particularly at high modulation levels.	Weak r-f power amplifier V8. Weak r-f oscillator V6. Distorted modulating wave from oscillator V2 or amplifier V3.	Check distortion of the modulating sine wave from modulator V5. Check by replacement of V8. Check r-f drive to power amplifier, should be 4 to 11 volts.
8. Internal modulation not possible.	Loose 3-watt lamp 11 in modulation oscillator V2.	Tighten lamp in socket.
9. RF output signal does not go to zero when generator is switched to PULSE operation and no pulses are applied.	Weak cathode follower V4 in modulator.	Replace V4.

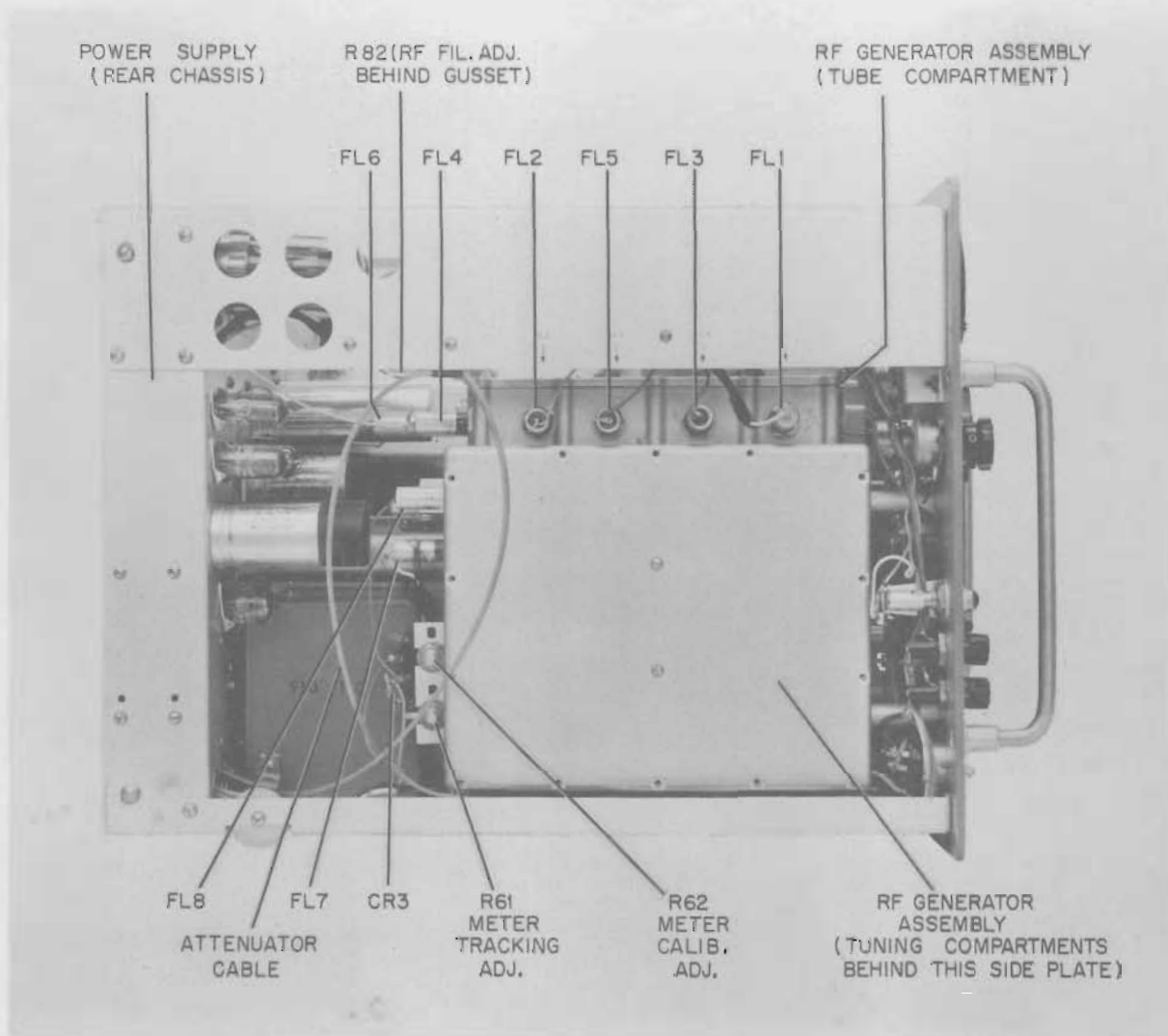

Fig. 12. Model 608D Signal Generator Right Side View,
Cabinet Removed

608D 5/19/55 Serial 192 and above #608D006

608D 5/19/55 Serial 192 and above #608D006

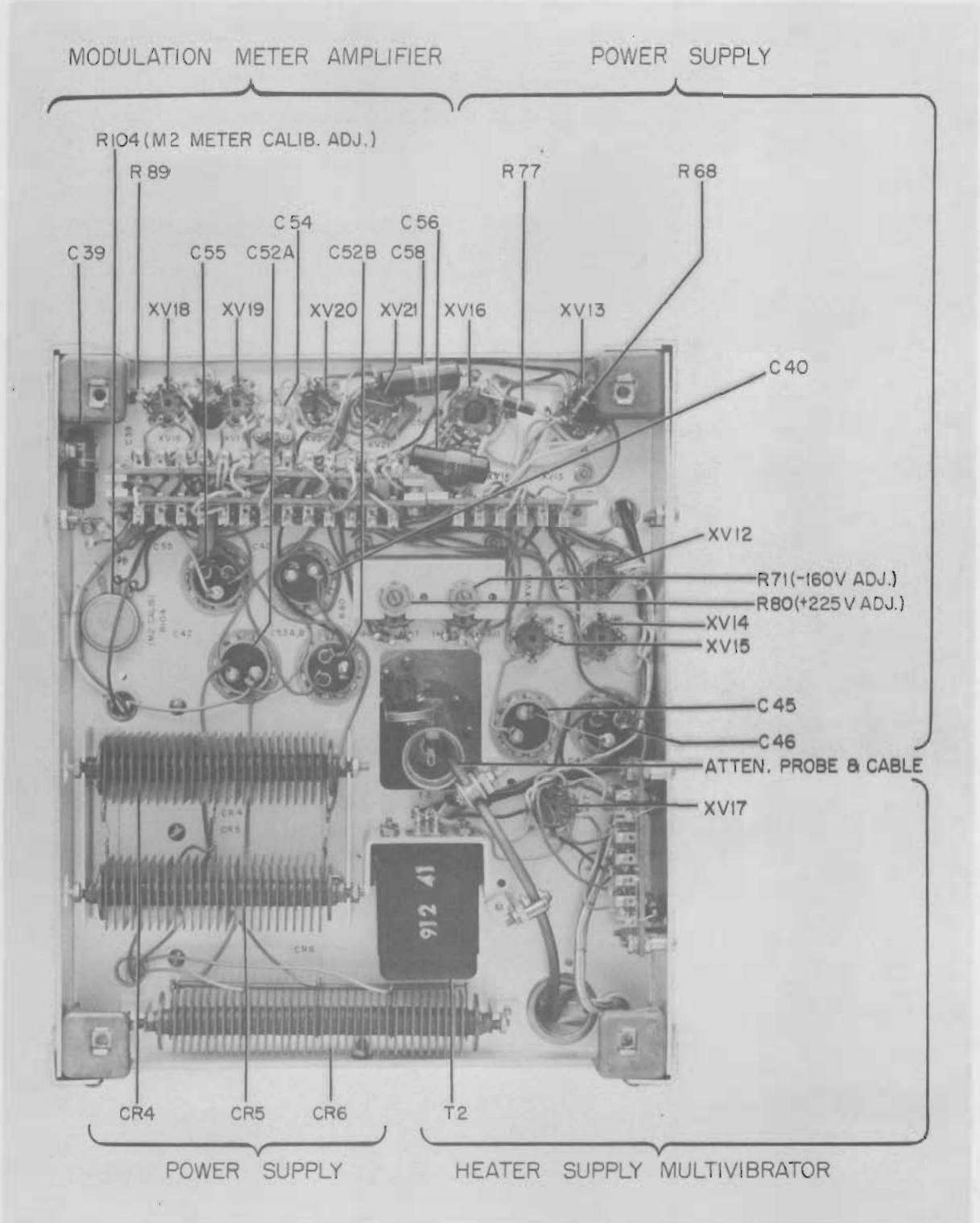

Fig. 13. Model 608D Signal Generator Rear View, Cabinet Removed

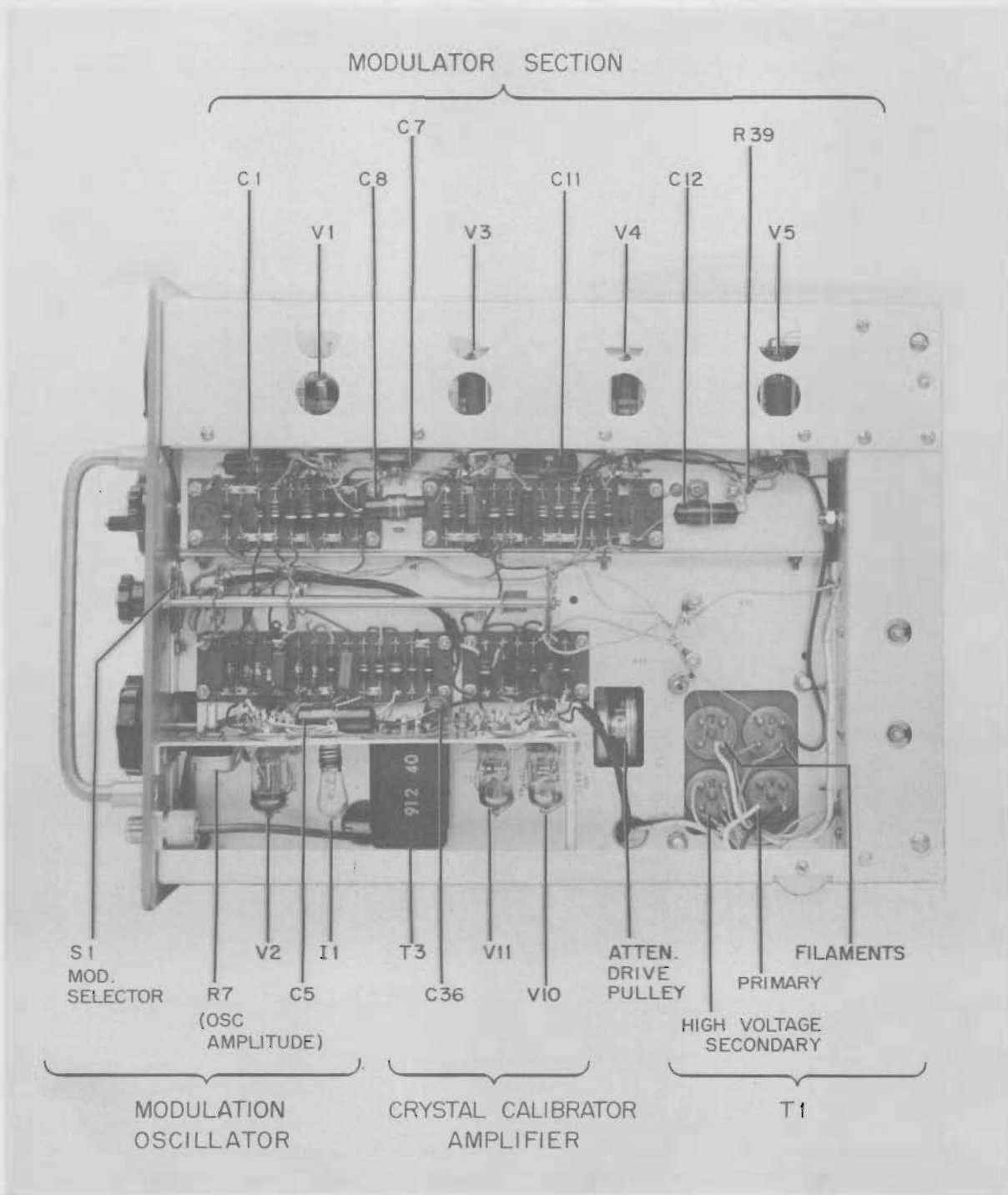

Fig. 14. Model 608D Signal Generator Left Side View, Cabinet Removed

608D 5/19/55 Serial 192 and above #608D006

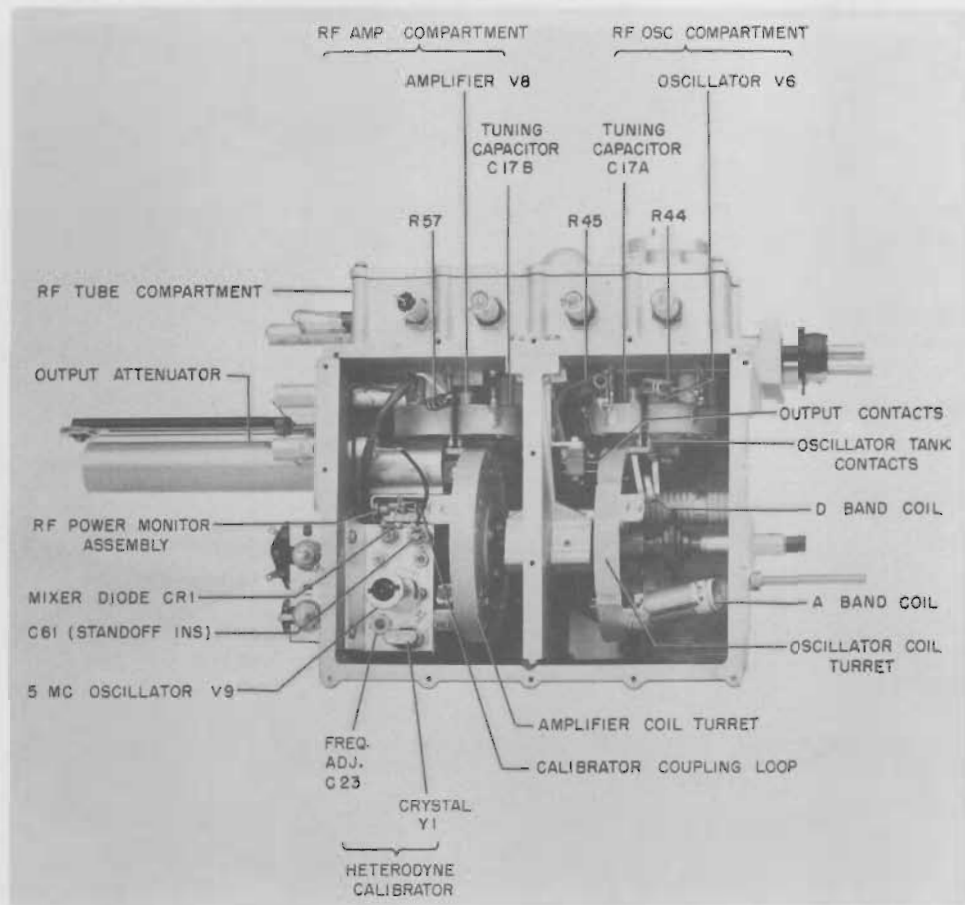

Fig. 15. R-F Generator Assembly, Side Plate Removed to Show Tuning Compartments

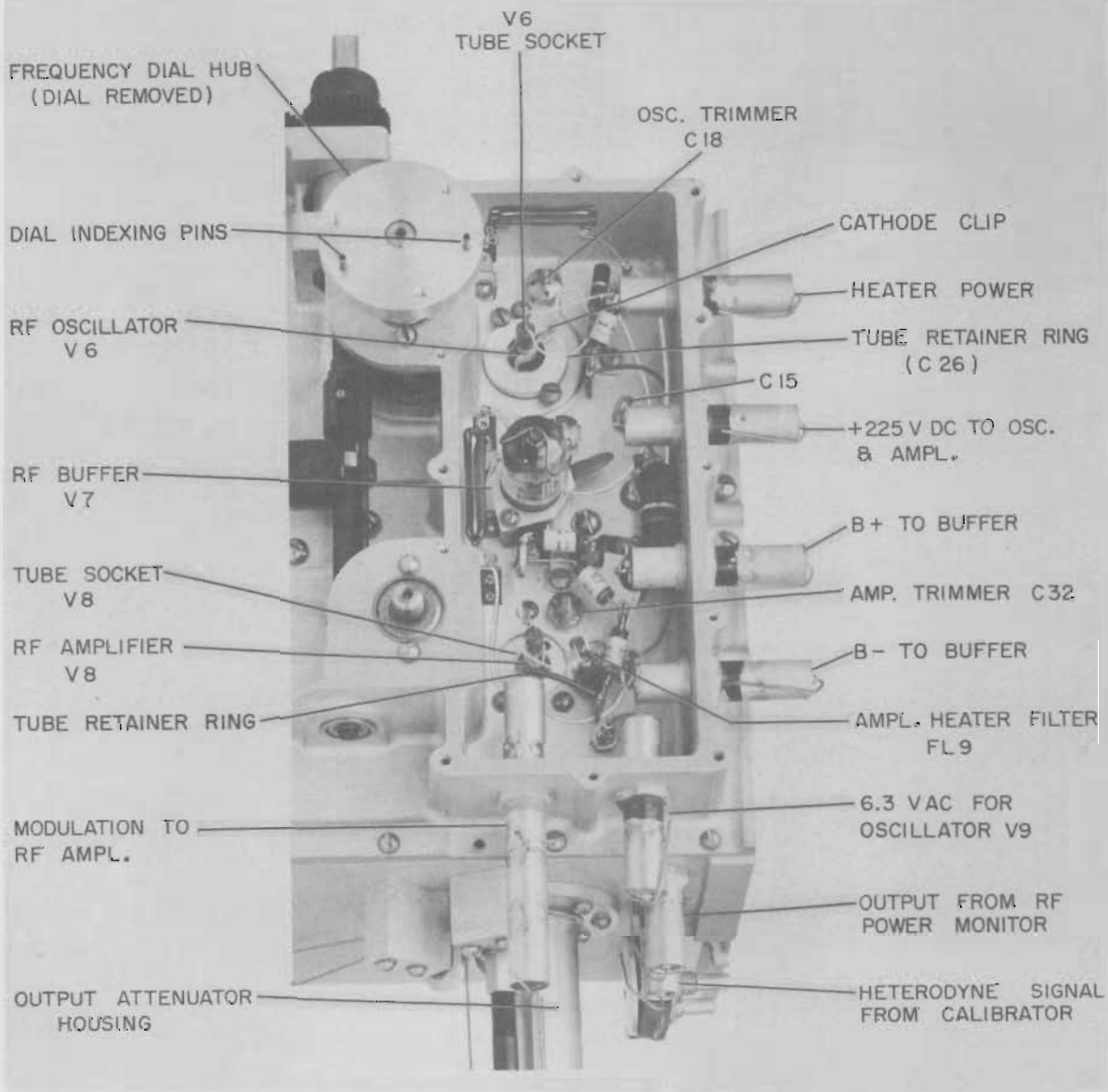
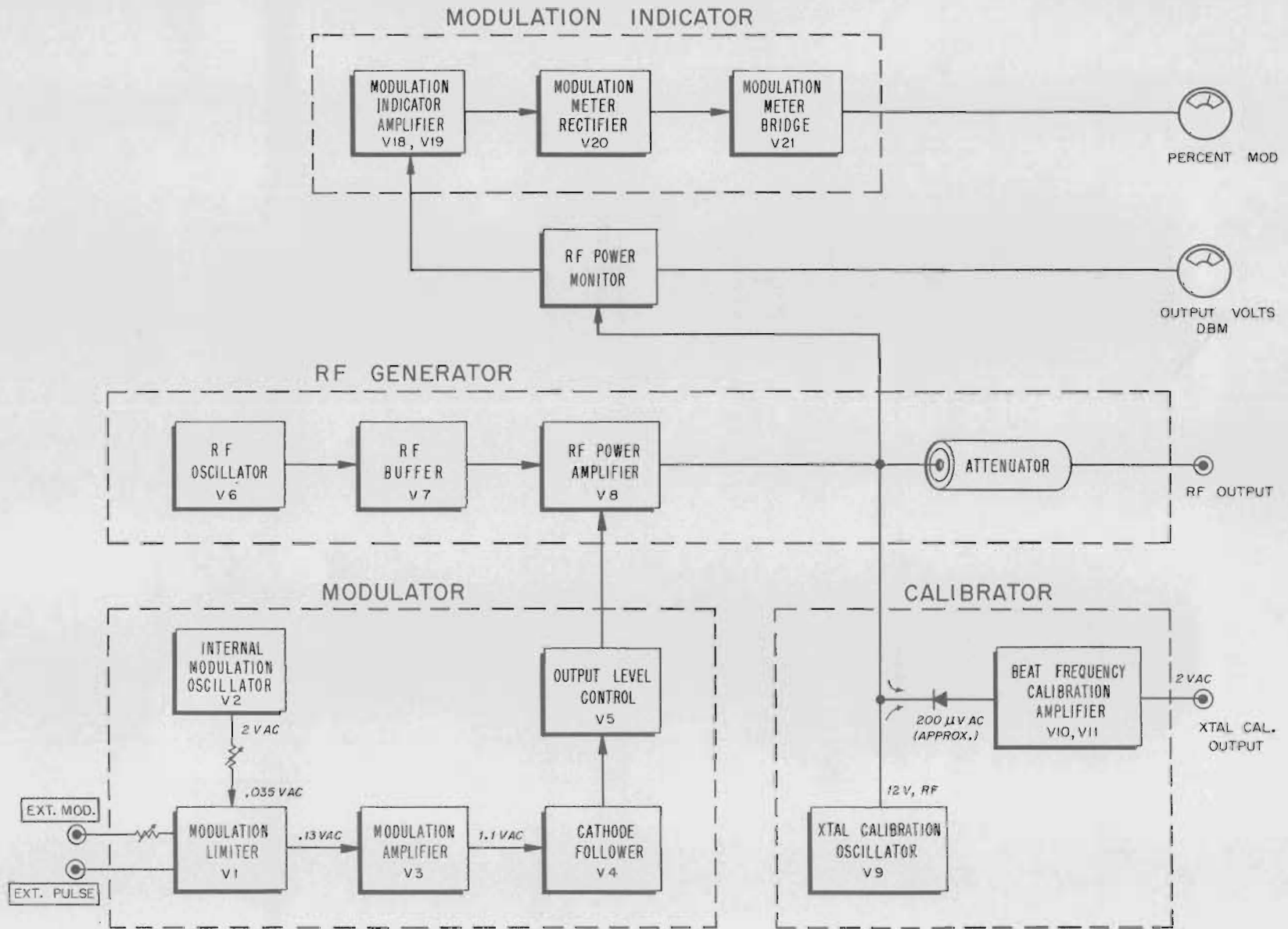

Fig. 16. Tube Compartment of R-F Generator Assembly,
Frequency Dial and Cover Plate Removed

608D 5/19/55 Serial 192 and above #608D006



-69-

Fig. 17. Signal Tracing Block Diagram

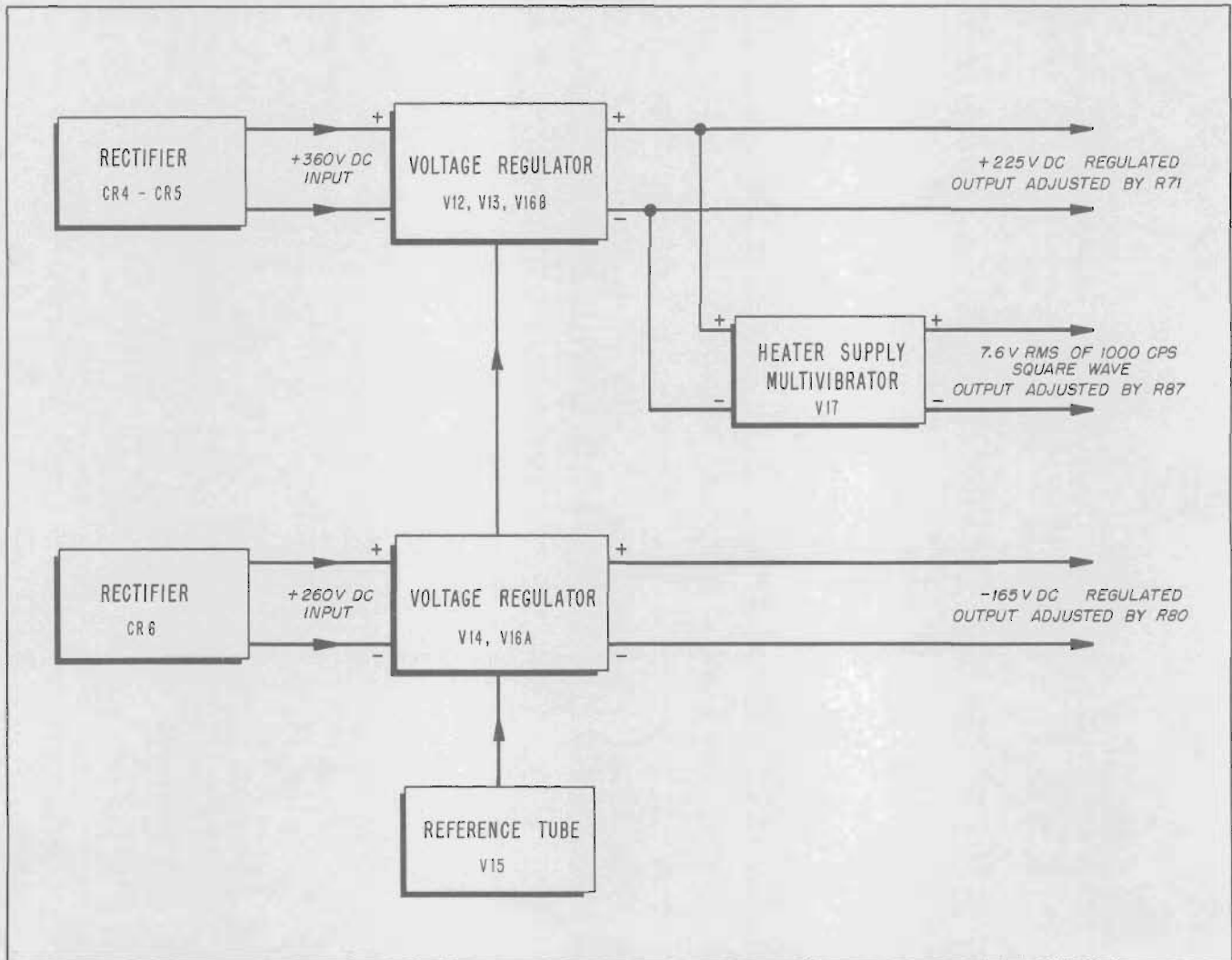

Fig. 17a. Block Diagram of Power Supply

NOTES PERTAINING TO ALL
TUBE SOCKET VOLTAGE-RESISTANCE DIAGRAMS

1. CONDITIONS OF MEASUREMENT

Unless otherwise noted, measurements made with respect to chassis ground using voltmeter having 20,000-ohm-per-volt sensitivity and with front panel controls at the following settings:

FREQUENCY --- 100 MC
MOD. SELECTOR --- 1000 λ
MOD. LEVEL --- 30%
OUTPUT LEVEL --- Set Level

R71 and R80 in the power supply section were set to provide the normal supply voltages of +225v and -165v, respectively.

2. 20,000-ohm-per-volt meter cannot be used for this measurement since it will load the circuit and provide an erroneous reading. A vacuum-tube voltmeter should be used here.
3. Reading taken at minimum and maximum setting of OUTPUT LEVEL control.

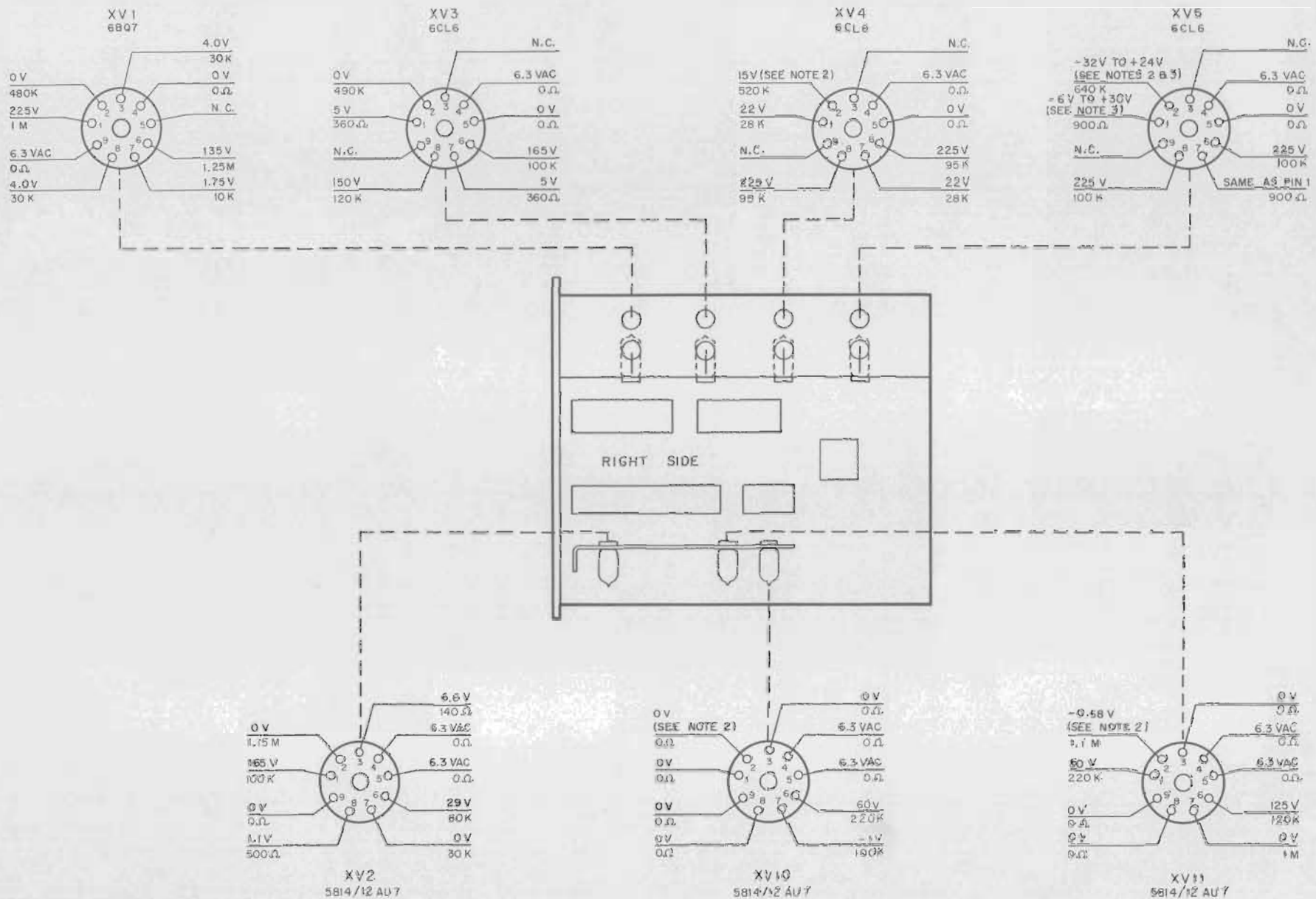
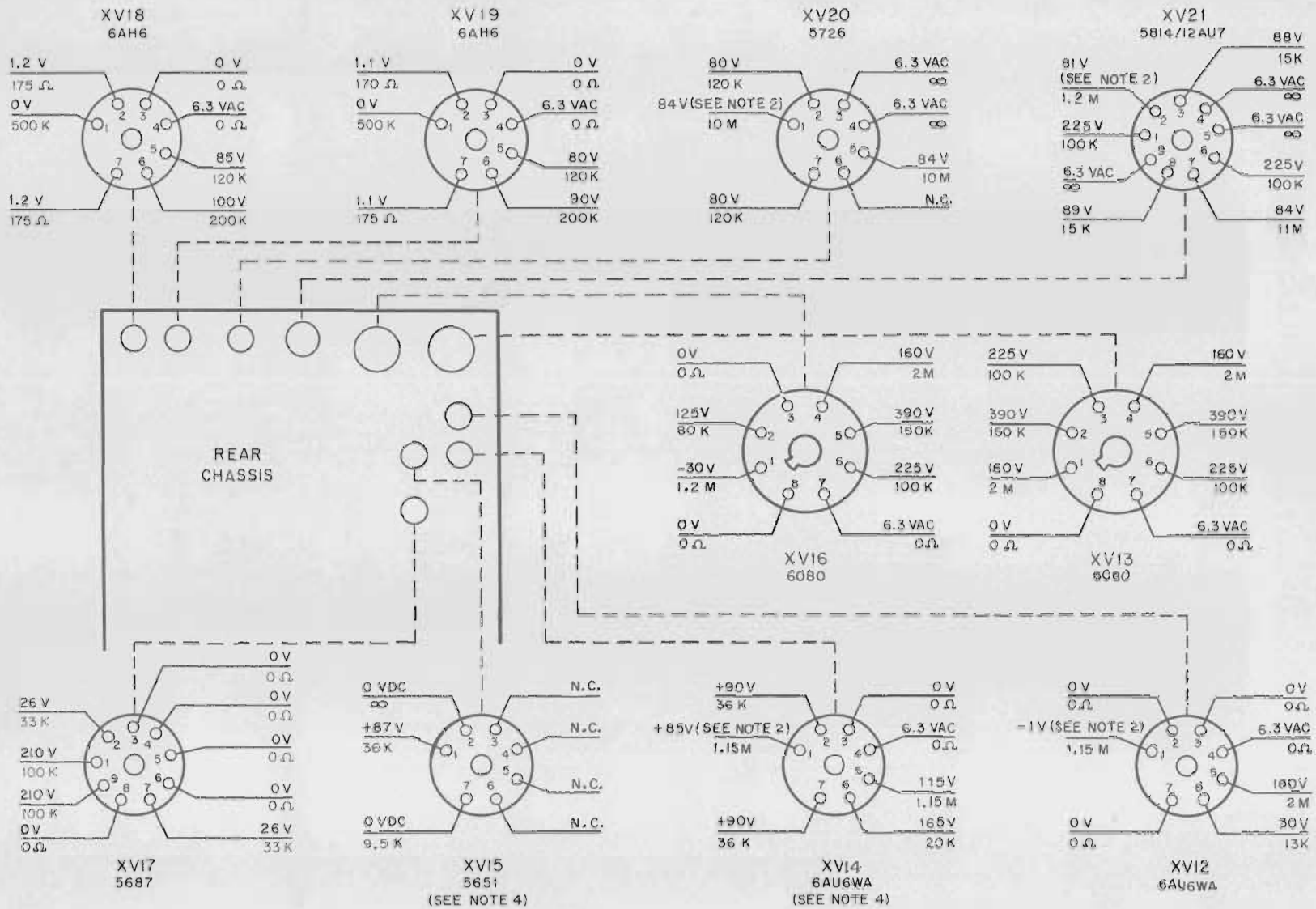

Fig. 18. Tube Socket Voltage and Resistance Diagram, Right Side Chassis



-73-

Fig. 19. Tube Socket Voltage and Resistance Diagram, Rear Chassis

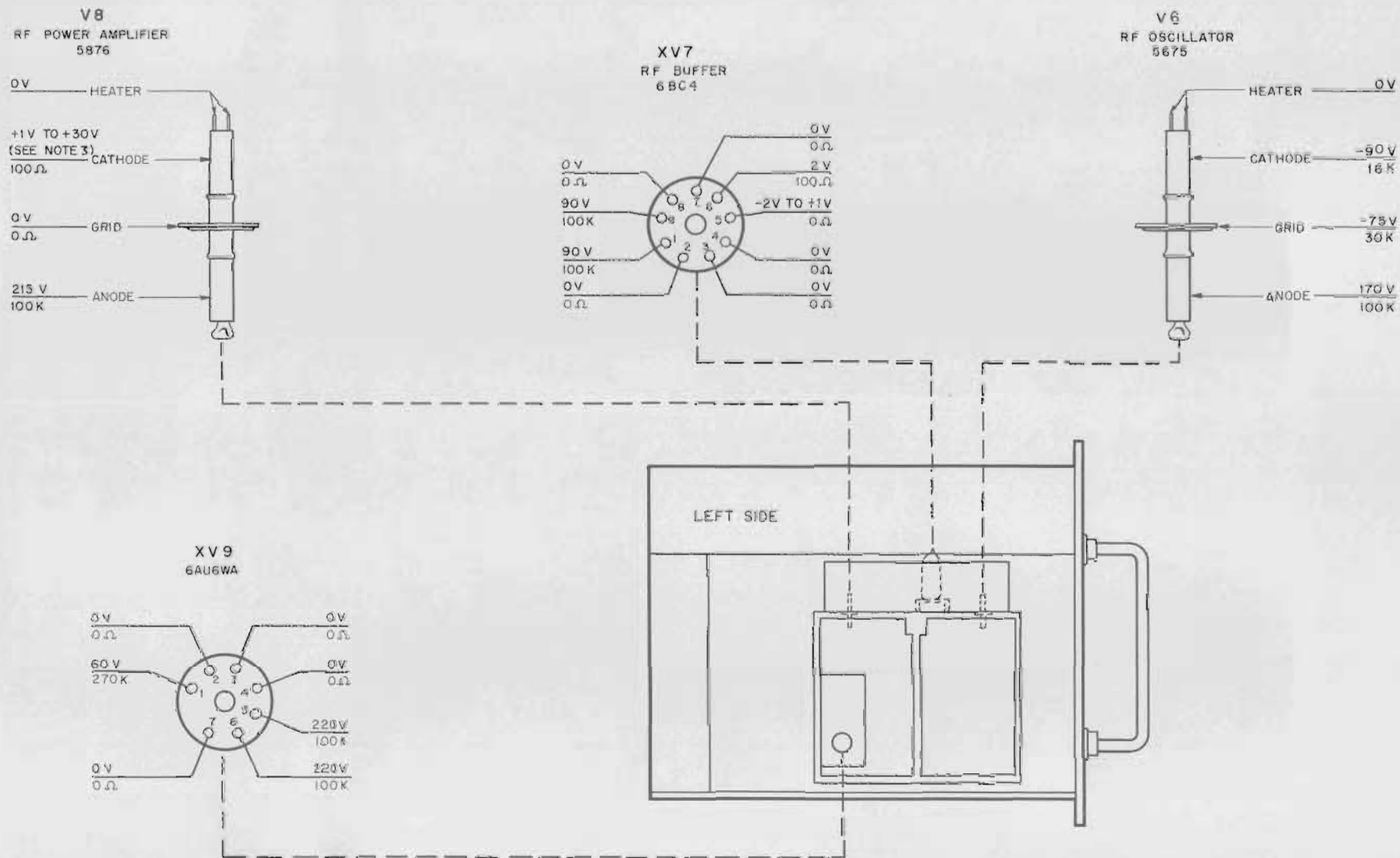

Fig. 20. Tube Socket Voltage and Resistance Diagram, R-F Generator Assembly

SECTION V
TABLE OF REPLACEABLE PARTS

NOTE

Any changes in the Table of Replaceable Parts will be listed on a Production Change sheet at the front of this manual.

When ordering parts from the factory always include the following information:

Instrument model number
Serial number
-hp- stock number of part
Description of part

TABLE OF REPLACEABLE PARTS

Circuit Ref.	Description	-hp- Stock No.	Mfr. * & Mfrs. Designation
C18, 32, 59	Capacitor: variable, glass dielectric .3 to 3 μf	13-3	Corning Glass Wks #680015
C23	Capacitor: variable, glass dielectric 1 to 12 μf	13-21	Corning Glass Wks. #683040
C37	Consists of insulated metal pin and brass sleeve	608A-34Q 608A-34P	HP HP
	CAPACITOR: fixed, mica dielectric, $\pm 10\%$, 500 vdcw (unless otherwise noted)		
C2, 3	5600, 300 vdcw	15-42	A, Type 1464X
C4	470, $\pm 5\%$	15-90	Z, KR 1347
C6, 50, 53	1800	14-47	V, Type OXM
C10	390, $\pm 5\%$	14-43	V, Type OXM
C13	100	14-100	V, Type OXM
C16	100, button type	15-53	Z, Type M-100
C25	50, (2 required)	512-112	HP
C29	56	15-48	Z, Type M-100
C33	65	608D-82	HP
	CAPACITOR: fixed, ceramic dielectric, $\pm 5\%$, 500 vdcw, value in μf (unless otherwise noted)		
C9, 34, 35, 41, 43, 44, 49, 51, 57, 66	10,000	15-43	A, Type BPD.01
C14, 15, 28, 31	1,000, $\pm 20\%$, feed-thru type	15-68	L, Style 327
C19	5,000	15-47	A, Type BPD.005
C20, 21	47	15-34	A, SI47 μf $\pm 5\%$ NPO

*See "List of Manufacturers Code Letters For Replaceable Parts Table."

TABLE OF REPLACEABLE PARTS

Circuit Ref.	Description	-hp- Stock No.	Mfr. * & Mfrs. Designation
C22	10, $\pm 0.5 \mu\mu\text{f}$	15-30	A, CI-1
C24	2.2, $\pm 10\%$	15-52	DD, #GA-4
C26, 65	2,000, $\pm 20\%$, disc type	15-80	A, BPD.002
C30	0.47	15-74	DD
C38, 64	550, $\pm 10\%$	15-37	Z, Type M-100
C60	5, $\pm 0.5 \mu\mu\text{f}$	15-29	A, CI-1
C61	5 (approx.) standoff insulator	34-9 (2 reqd.)	HP
	CAPACITOR: fixed, paper dielectric, $\pm 10\%$, 400 vdcw, value in μf (unless otherwise noted)		
C1, 8, 11, 12, 27, 36, 39, 56, 58	0.1, $\pm 20\%$	16-35	CC, 68P10404
C5	0.22	16-48	CC, 67P22494
C47, 48	0.01, 600 vdcw	16-11	CC, 73P10306
C68	Special trimmer, fine freq. adj.	608D-59H	HP
	CAPACITOR: fixed, electrolytic, 450 vdcw, value in μf		
C7AB, C52AB, C55, 46AB	10, dual section	18-32	J, CE42F100R
C40, 42	80	18-34	J, CE41F800R
C45	45	18-33	J, CE41F450R
CR1/7	Rectifier, crystal	212-G11A	HP
CR2/3	Rectifier, crystal	212-1N82	HP
CR4/5	Rectifier, metallic	212-104	Int'l. Rect. B13D1NTBGX

*See "List of Manufacturers Code Letters For Replaceable Parts Table."

TABLE OF REPLACEABLE PARTS

Circuit Ref.	Description	-hp- Stock No.	Mfr. * & Mfrs. Designation
CR6	Rectifier, metallic	212-103	Int'l. Rect. A9B1NTBGX
F1	Fuse, 3.2 amp	211-45	T, 31303.2
F3	Fuse, .25 amp	211-6	T, 312.250
FL1/4/7	Filter, Radio Frequency: red	608A-27A	HP
FL2/3/5	Filter, Radio Frequency: green	608A-27D	HP
FL6	Filter, Radio Frequency: blue	608D-27C	HP
FL8	Filter, Radio Frequency: white	608D-27B	HP
FL9	Filter, R. F. Choke	608D-60D	HP
I1	Lamp, Incandescent: 3 watt	211-4	O
I3, I4	Lamp, dial illuminating, lamp, pilot	211-47	O
J1/2	Connector, BNC female	125-UG-290/U	HP
J3	Connector, Receptacle: phone jack	124-11	KK, SF-JAX-21
J4	Panel Jack, body	G-76A	HP
J4D	Bushing	G-76A-1	HP
J4A	Bead "A" (large)	G-76A-2	HP
J4B	Bead "B" (small)	G-76A-3	HP
J4C	Spacer	G-76A-4	HP
J4E	Contact, female	125-49	HP
J5	Connector, Receptacle: motor base socket	125-25	O, #2711

*See "List of Manufacturers Code Letters For Replaceable Parts Table."

TABLE OF REPLACEABLE PARTS

Circuit Ref.	Description	-hp- Stock No.	Mfr. * & Mfrs. Designation
L6/7	Coil, Variable: 10-20 μ h	48-22	MM, #32
L8	Choke, R.F.: 4.5 μ h	608D-60C	HP
L9	Choke, R.F.: 4.5 μ h	608D-60J	HP
L10/11	Choke, R.F.: 4.5 μ h	608D-60K	HP
M1	Meter, Microammeter: 50 microamp	112-62	Weston #301
M2	Meter, Milliammeter: 1 milliamp	112-56	Weston #301
O4/5/6	Knob, round, w/skirt	37-11	Kurz-Kasch Inc., S-380-64-DD-L-522
	Knob, round, (fine freq. adjust)	608D-74B	HP
O3	Knob, round, 3/4 in. dia.	608D-74A	HP
O7/8	Knob, bar	37-19	Dimco-Gray Co, 46A42256
O10	Knob, round, w/skirt, counterbored	212A-74A	HP
O12	Knob, attenuator, with dial	608D-40A	HP
O13	Knob, frequency vernier dial	612A-74	HP
O14	Handle, frequency vernier	G-74A	HP
O15	Dial, frequency vernier	608D-40B	HP
O16	Window, attenuator dial	G-99C	HP
O17	Knob, fine frequency adjust	608D-74B	HP
	RESISTOR: fixed, composition, 1/5 watt, $\pm 10\%$ tolerance		
R60, 109	100 ohms	21-100	F, Type 997CX
R108	27 ohms	21-27	F, Type 997CX

*See "List of Manufacturers Code Letters For Replaceable Parts Table."

TABLE OF REPLACEABLE PARTS

Circuit Ref.	Description	-hp- Stock No.	Mfr. * & Mfrs. Designation
R110	47 ohms	21-47	F, Type 997CX
R111	150 ohms	21-150	F, Type 997CX
	RESISTOR: fixed, composition, 1/2 watt, $\pm 10\%$ tolerance, (value in ohms unless otherwise noted)		
R16, 24, 26 32, 39, 89, 95	56	23-56	B, EB 5601
R41	180	23-180	B, EB 1811
R46	12	23-12	B, EB 1201
R48	270K	23-270K	B, EB 2741
R49	470	23-470	B, EB 4711
R51	100K	23-100K	B, EB 1041
R88, 94	470K	23-470K	B, EB 4741
R114	1000	23-1000	B, EB 1021
R117	100	23-100	B, EB 1011
	RESISTOR: fixed, composition, 1 watt, $\pm 10\%$ tolerance (value in ohms unless otherwise noted)		
R1, 115	56K	24-56K	B, GB 5631
R9, 66, 70	150K	24-150K	B, GB 1541
R10, 119	1500	24-1.5K	B, GB 1521
R11, 22, 53 69, 76, 78, 101	1M	24-1M	B, GB 1051
R12	100K	24-100K	B, GB 1041
R8, 13, 68, 77, 118	1000	24-1000	B, GB 1021

*See "List of Manufacturers Code Letters For Replaceable Parts Table."

TABLE OF REPLACEABLE PARTS

Circuit Ref.	Description	-hp- Stock No.	Mfr. * & Mfrs. Designation
R15, 23, 30, 38	470K	24-470K	B, GB 4741
R19, 50	10K	24-10K	B, GB 1031
R25, 82	330	24-330	B, GB 3311
R29	39K	24-39K	B, GB 3931
R31	560K	24-560K	B, GB 5641
R34, 52, 54	120K	24-120K	B, GB 1241
R36	180	24-180	B, GB 1811
R40	180K	24-180K	B, GB 1841
R57	470	24-470	B, GB 4711
R65	12K	24-12K	B, GB 1231
R67	1.8M	24-1.8M	B, GB 1851
R72, 79, 81	220K	24-220K	B, GB 2241
R73	27K	24-27K	B, GB 2731
R75, 83, 86	33K	24-33K	B, GB 3331
R84, 85	68K	24-68K	B, GB 6831
R90, 91	82	24-82	B, GB 8201
R93, 98	82K	24-82K	B, GB 8231
R96	150	24-150	B, GB 1511
R99	1800	24-1800	B, GB 1821
R100	10M	24-10M	B, GB 1061
R105	220	24-220	B, GB 2211

*See "List of Manufacturers Code Letters For Replaceable Parts Table."

TABLE OF REPLACEABLE PARTS

Circuit Ref.	Description	-hp- Stock No.	Mfr. * & Mfrs. Designation
	RESISTOR: fixed, composition, 2 watt, $\pm 10\%$		
R14, 44	12K	25-12K	B, HB 1231
R17, 18	8.2K	25-8.2K	B, HB 8221
R20	2.2K	25-2.2K	B, HB 2221
R21	18K	25-18K	B, HB 1831
R28, 92, 97, 102, 107	22K	25-22K	B, HB 2231
R42	470	25-470	B, HB 4711
R55	27K	25-27K	B, HB 2731
R74	68K	25-68K	B, HB 6831
	RESISTOR: fixed, wirewound, $\pm 10\%$, 10 watt (unless otherwise noted)		
R27	5K, $\pm 1\%$, 5 watt	26-45	Dale Prod., Inc. #RS-5
R33	15K	26-25	S, Type 1-3/4E
R43	5000	26-8	S, Type 1-3/4E
R45	3000	26-3	S, Type 1-3/4E
R47	6300	26-61	S, Type 1-3/4E
R116	7500	26-9	S, Type 1-3/4E
R121	1/2, $\pm 20\%$, 5 watt	26-76	S
R35	7500, $\pm 5\%$, 20 watt	27-24	S

*See "List of Manufacturers Code Letters For Replaceable Parts Table."

TABLE OF REPLACEABLE PARTS

Circuit Ref.	Description	-hp- Stock No.	Mfr. * & Mfrs. Designation
	RESISTOR: variable, composition $\pm 10\%$		
R2	20K, 2.25 watt, R.H. log taper	210-70	HP
R7, 61	2000, $\pm 20\%$	210-14	HP
R37A,B	2K-50K dual	210-71	HP
R56	1M, $\pm 20\%$, R. H. log taper	210-66	HP
R62	25K, $\pm 20\%$, 1 watt	210-11	G, BA1-010-1990
R71, 80	50K	210-36	HP
R87	1500, linear taper	210-33	HP
R104, 106	10K, linear taper	210-35	HP
S1	Switch, Rotary: 5 position	310-138	Oak Mfg. Co, 61354HC
S3	Switch, Toggle	310-21	HP
T1	Transformer, Power	910-110	HP
T2	Transformer, Audio: filament type	912-45	HP
T3	Transformer, Audio: phone	912-40	HP
V1	Tube: 6BQ7	212-6BQ7	ZZ
V2/21	Tube: 12AU7	212-12AU7	ZZ
V3/4/5	Tube: 6CL6	212-6CL6	ZZ
V6	Tube: 5675	212-5675	ZZ
V7	Tube: 6BC4	212-6BC4	ZZ
V8	Tube: 5876	212-5876	ZZ
V9/12/14	Tube: 6AU6	212-6AU6	ZZ
V10/11	Tube: 12AT7	212-12AT7	ZZ
V13/16	Tube: 6080	212-6080	ZZ
V15	Tube: 5651	212-5651	ZZ
V17	Tube: 5687	212-5687	ZZ
V18/19	Tube: 6AH6	212-6AH6	ZZ
V20	Tube: 6AL5	212-6AL5	ZZ

*See "List of Manufacturers Code Letters For Replaceable Parts Table."

TABLE OF REPLACEABLE PARTS

Circuit Ref.	Description	-hp- Stock No.	Mfr. * & Mfrs. Designation
W1	Power Cord	812-68	HP
XF1	Fuseholder	140-16	T, 342003
XI1	Lampholder, candelabra base	145-15	Leecraft Mfg. Co. #659.1
XI3	Lampholder, dial illuminating	145-13	#708-1
XI1A	Lamp, locking spring	146-15	HP
XI4	Pilot light holder	145-2	II, 810B-121
XV1,2,3,4,5,7,10,11,17,21	Tube socket, 9 pin noval	120-10	Elko. 377PH
XV9,12,14,15,18,19,20	Tube socket, 7 pin miniature	120-11	Elko. 316PH
XV13,16	Tube socket, octal	120-7	Elko. 335BC
XV6/8	Tube socket, pencil triode filament contact assembly, oscillator cathode	120-12	H, 54A16325
	Spacer, Osc. Grid	608D-59A-4	HP
	Spring, detent	608D-59C	HP
	Roller, detent	608D-59D	HP
25	Turret Assembly, Amplifier	608D-60A	HP
	Turret Blank, Amplifier	608D-83A	HP
	Turret Blank, Oscillator	608D-83B	HP
	Turret Assembly, Oscillator	608D-60B	HP
	Attenuator Probe Assembly	608D-34	HP
	Attenuator Drive Cable, 36" long	816-3-608-D	HP
	Frequency Dial Window	608D-83C	HP
	Bezel, frequency window	608D-83E	HP
	Clamp, tube, for V13/16	140-46	HP

*See "List of Manufacturers Code Letters For Replaceable Parts Table."

TABLE OF REPLACEABLE PARTS

Circuit Ref.	Description	-hp- Stock No.	Mfr. * & Mfrs. Designation
	Clamp, tube, spring (short)	140-12	HP
	Clamp, tube, spring (Med.)	140-13	HP
	Contact Assy. for oscillator pickup coil	608A-100K	HP
	Contact, Osc. grid	608A-100V	HP
	Contact, Amp. cathode	608A-100W	HP
	Insulator Card, attenuator	608A-34C	HP
	Insulator, ceramic shoulder bushing	34-9	Gen. Ceramics Corp. #1493-00
	Insulator, standoff, ceramic	34-34	Gen. Ceramics Corp. #1023-04-3/4"
	Insulator, standoff, ceramic 1/2" long x 1/2" dia.	34-11	G
	Spacer, ceramic 5/8" long, 1-1/2" dia.	34-10	HP
	Wrench, spanner	612A-38A	HP
XY1	Socket, Crystal	120-37	H, #54A-17358
Y1	Crystal, 5 megacycle	41-34	Knight

*See "List of Manufacturers Code Letters For Replaceable Parts Table."

LIST OF MANUFACTURERS CODE LETTERS
FOR REPLACEABLE PARTS TABLE

<u>Code Letter</u>	<u>Manufacturer</u>
A	Aerovox Corp.
B	Allen-Bradley Co.
C	Amperite Co.
D	Arrow, Hart and Hegeman
E	Bussman Manufacturing Co.
F	Carborundum Co.
G	Centralab
H	Cinch Manufacturing Co.
HP	Hewlett-Packard
I	Clarostat Manufacturing Co.
J	Cornell Dubilier Electric Co.
K	Hi-Q Division of Aerovox Corp.
L	Erie Resistor Corp.
M	Federal Telephone and Radio Corp.
N	General Electric Co.
O	General Electric Supply Corp.
P	Girard-Hopkins
R	International Resistance Co.
S	Lectrohm, Inc.
T	Littelfuse, Inc.
V	Micamold Radio Corp.
X	P. R. Mallory Co., Inc.
Z	Sangamo Electric Co.
AA	Sarkes Tarzian
CC	Sprague Electric Co.
DD	Stackpole Carbon Co.
EE	Sylvania Electric Products, Inc.
FF	Western Electric Co.
HH	Amphenol
II	Dial Light Co. of America
KK	Switchcraft, Inc.
LL	Gremer Mfg. Co.
MM	Carad Corp.
ZZ	Any tube having RETMA standard characteristics

90BY013

CLAIM FOR DAMAGE IN SHIPMENT

The instrument should be tested as soon as it is received. If it fails to operate properly, or is damaged in any way, a claim should be filed with the carrier. A full report of the damage should be obtained by the claim agent, and this report should be forwarded to us. We will then advise you of the disposition to be made of the equipment and arrange for repair or replacement. Include model number, type number and serial number when referring to this instrument for any reason.

WARRANTY

Hewlett-Packard Company warrants each instrument manufactured by them to be free from defects in material and workmanship. Our liability under this warranty is limited to servicing or adjusting any instrument returned to the factory for that purpose and to replace any defective parts thereof (except tubes, fuses and batteries). This warranty is effective for one year after delivery to the original purchaser when the instrument is returned, transportation charges prepaid by the original purchaser, and which upon our examination is disclosed to our satisfaction to be defective. If the fault has been caused by misuse or abnormal conditions of operation, repairs will be billed at cost. In this case, an estimate will be submitted before the work is started.

If any fault develops, the following steps should be taken:

1. Notify us, giving full details of the difficulty, and include the model number, type number and serial number. On receipt of this information, we will give you service instruction or shipping data.
2. On receipt of shipping instruction, forward the instrument prepaid, and repairs will be made at the factory. If requested, an estimate of the charges will be made before the work begins provided the instrument is not covered by the warranty.

SHIPPING

All shipments of Hewlett-Packard instruments should be made via Railway Express. The instruments should be packed in a wooden box and surrounded by two to three inches of excelsior or similar shock-absorbing material.

DO NOT HESITATE TO CALL ON US

HEWLETT-PACKARD COMPANY

Laboratory Instruments for Speed and Accuracy

395 PAGE MILL ROAD



PALO ALTO, CALIFORNIA

Nov. 1955

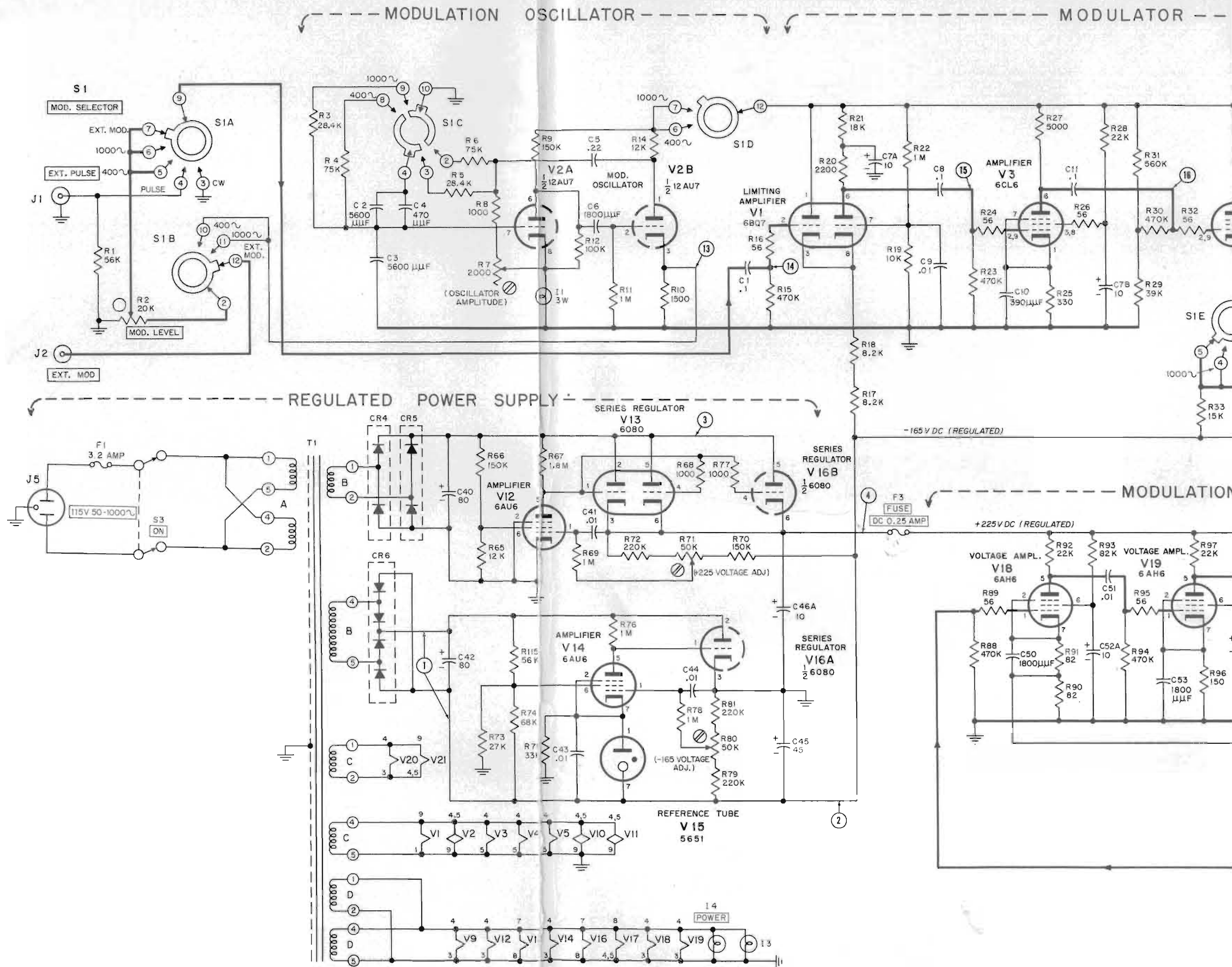

OSCILLATOR

MODULATOR

RF OSCILLATOR TUNING COMPARTMENT

RF GENERATOR ASS

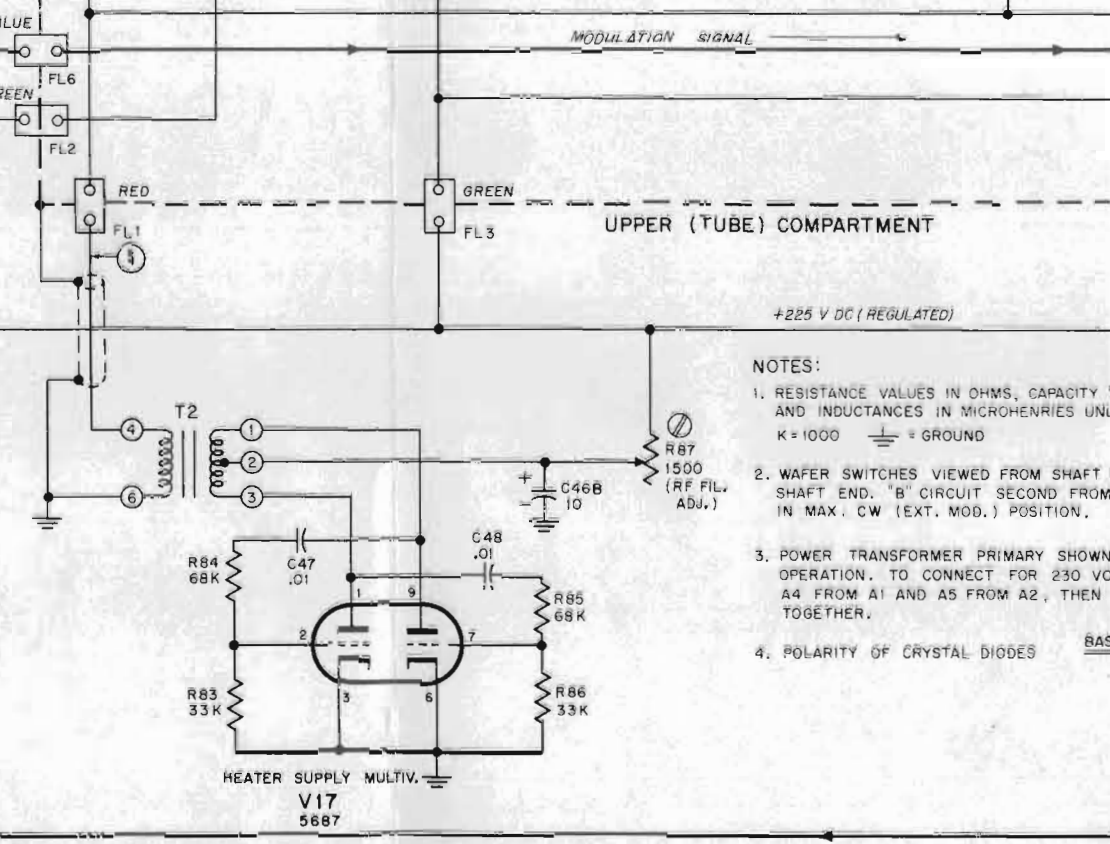
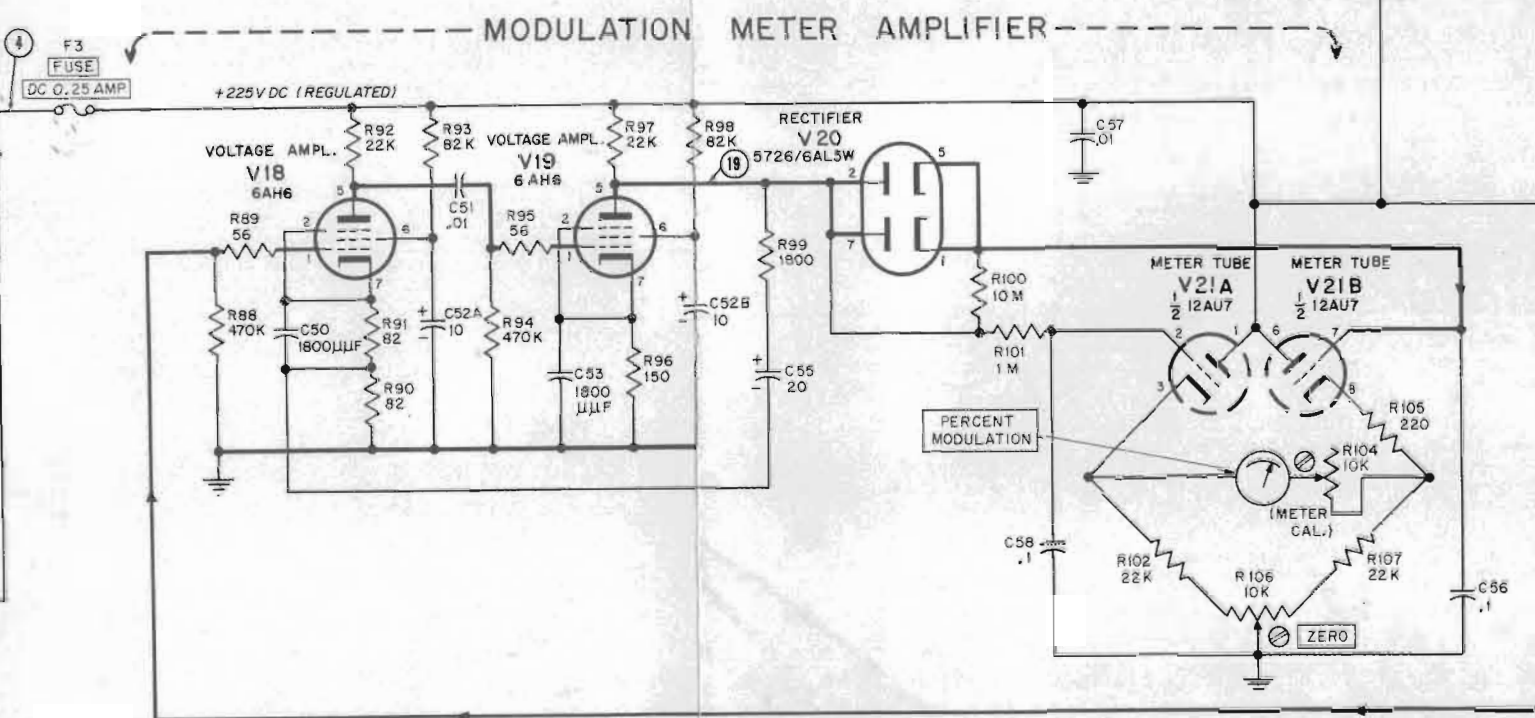
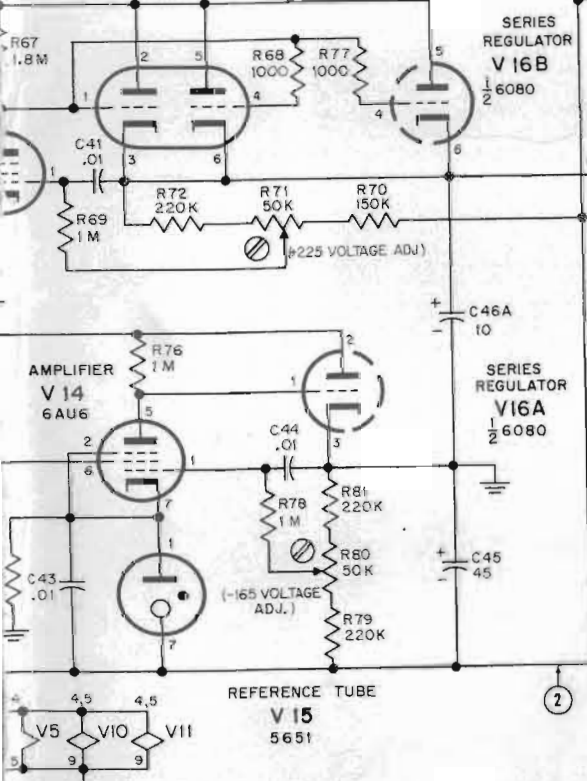
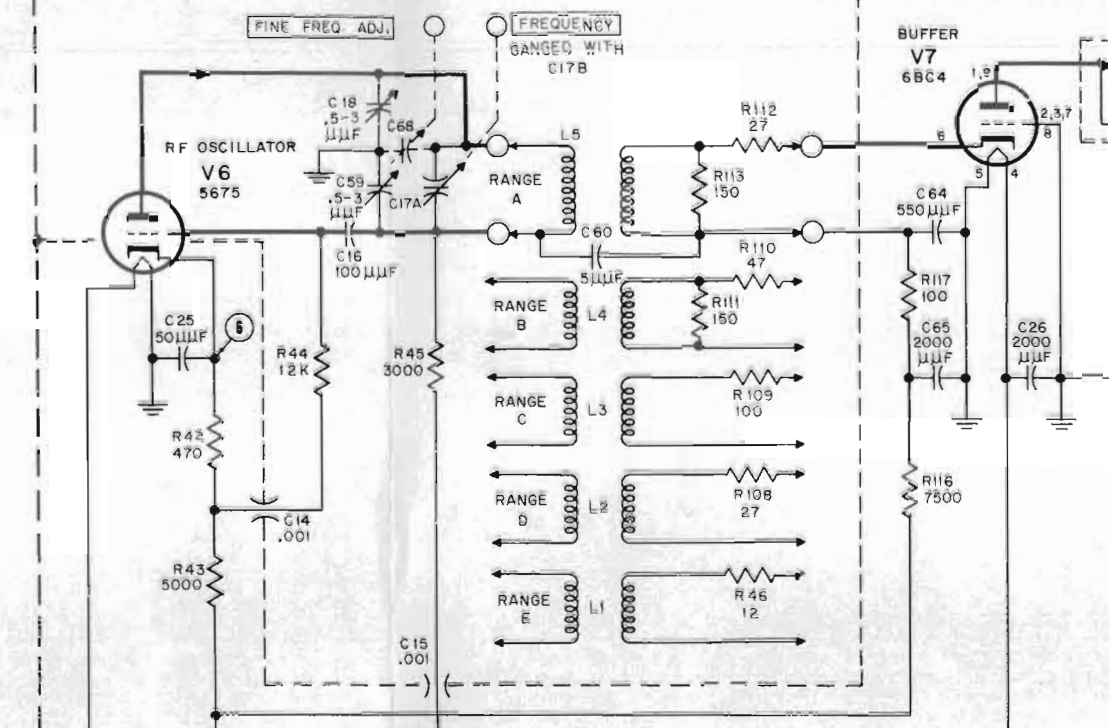
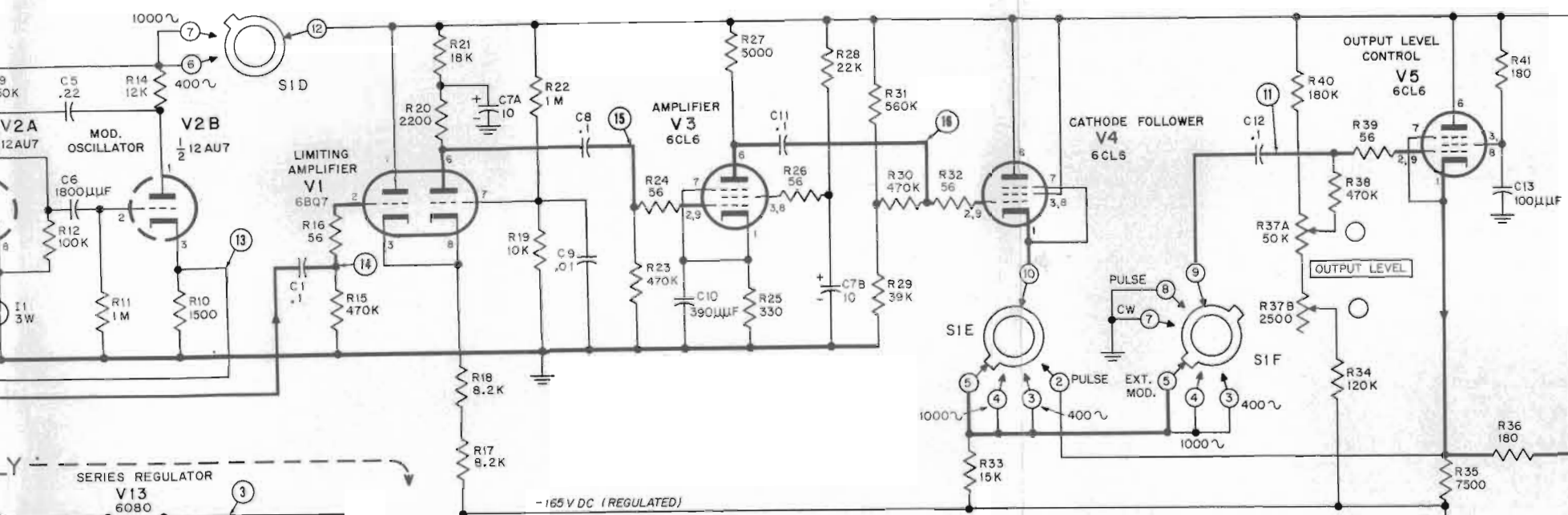

- NOTES:
1. RESISTANCE VALUES IN OHMS, CAPACITY AND INDUCTANCES IN MICROHENRIES UNLESS OTHERWISE SPECIFIED. K = 1000. \perp = GROUND.
 2. WAFER SWITCHES VIEWED FROM SHAFT END. "B" CIRCUIT SECOND FROM "A" IN MAX. CW (EXT. MOD.) POSITION.
 3. POWER TRANSFORMER PRIMARY SHOWN FOR 230 VAC OPERATION. TO CONNECT FOR 230 VAC, A4 FROM A1 AND A5 FROM A2, THEN TOGETHER.
 4. POLARITY OF CRYSTAL DIODES

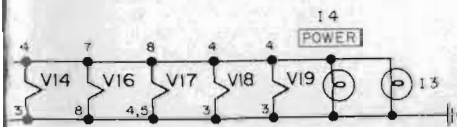

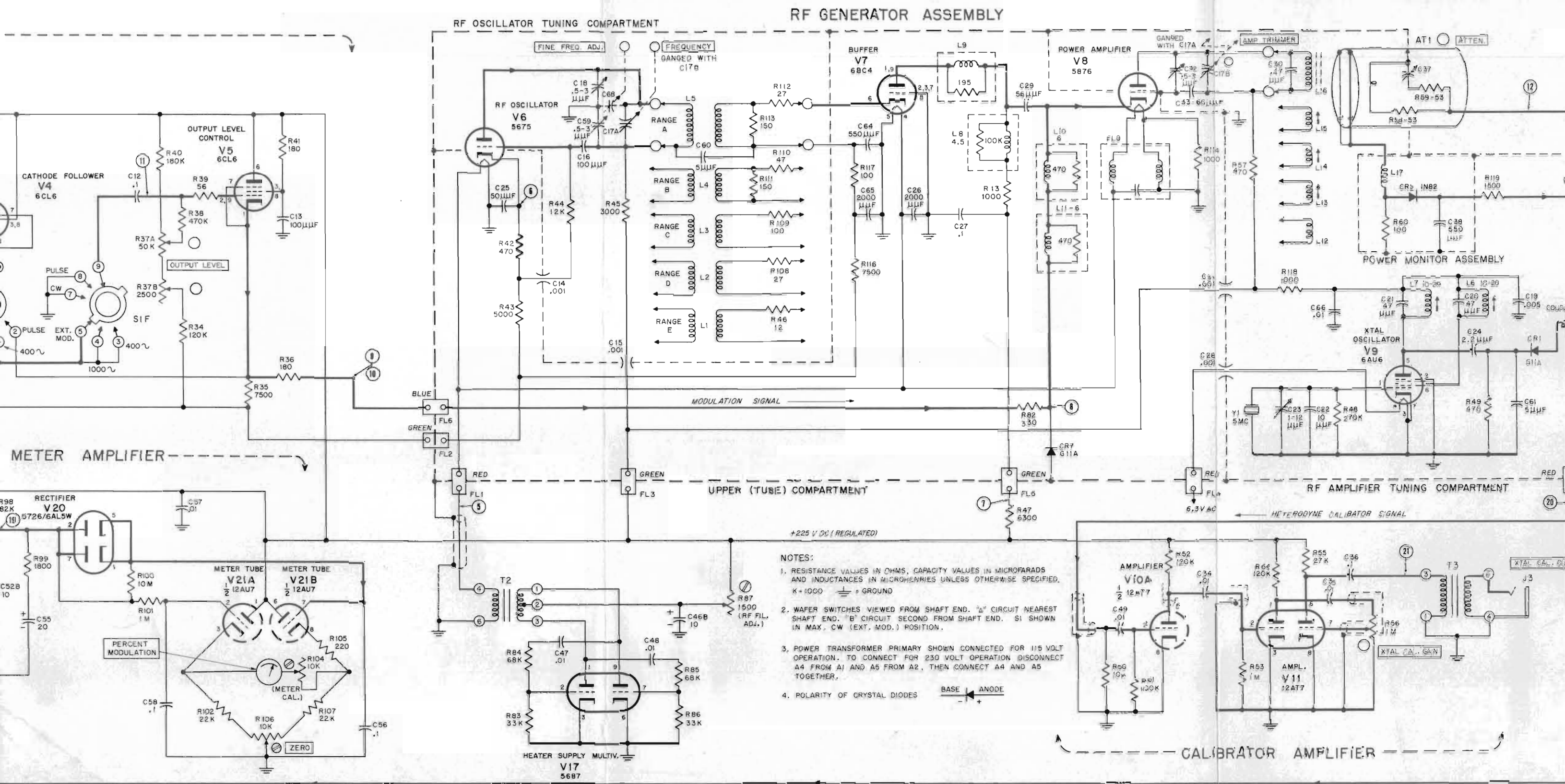
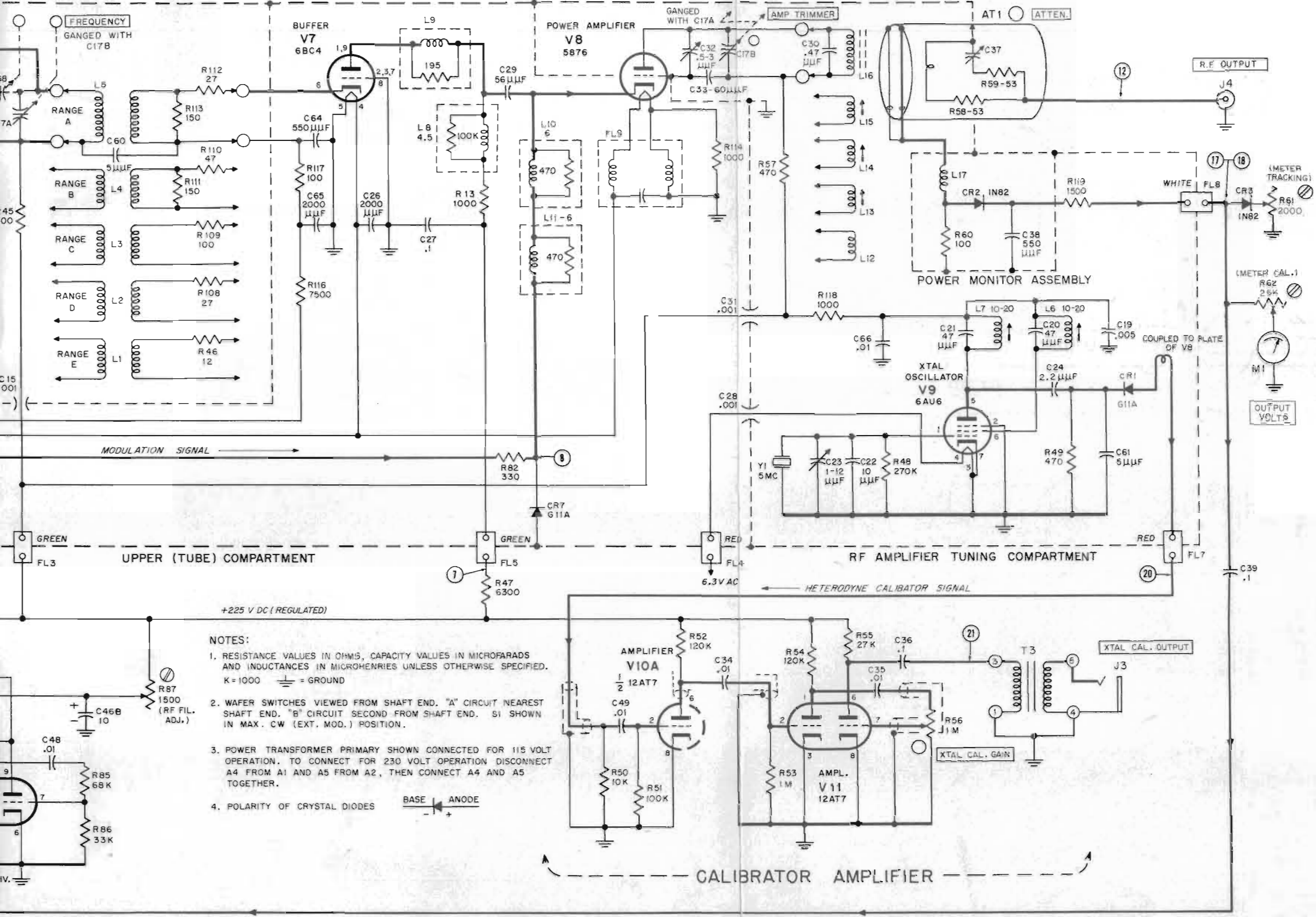

Figure 4-16 Schematic Diagram of Model 608D S

Serial number 192 and above

COMPARTMENT

RF GENERATOR ASSEMBLY



NOTES:

1. RESISTANCE VALUES IN OHMS, CAPACITY VALUES IN MICROFARADS AND INDUCTANCES IN MICROHENRIES UNLESS OTHERWISE SPECIFIED. K=1000 ⏏ = GROUND
2. WAFER SWITCHES VIEWED FROM SHAFT END. "A" CIRCUIT NEAREST SHAFT END. "B" CIRCUIT SECOND FROM SHAFT END. S1 SHOWN IN MAX. CW (EXT. MOD.) POSITION.
3. POWER TRANSFORMER PRIMARY SHOWN CONNECTED FOR 115 VOLT OPERATION. TO CONNECT FOR 230 VOLT OPERATION DISCONNECT A4 FROM A1 AND A5 FROM A2, THEN CONNECT A4 AND A5 TOGETHER.
4. POLARITY OF CRYSTAL DIODES $\text{BASE} \leftarrow \text{ANODE}$

Figure 4-16 Schematic Diagram of Model 508D Signal Generator

Serial number 192 and above